

Temperature Control for Research and Industry

**Model Gemini
Manual**

For Serial Number

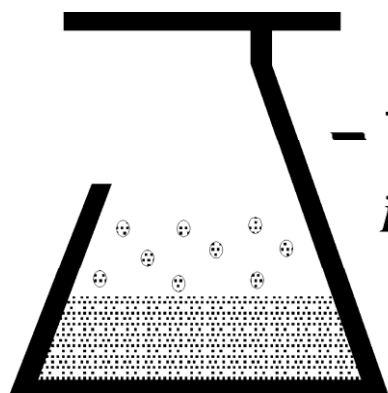

- KEM Scientific, Inc.
Instruments for Science from Scientists

Warranty

J-KEM Scientific, Inc. warrants this unit to be free of defects in materials and workmanship and to give satisfactory service for a period of 12 months from date of purchase. If the unit should malfunction, it must be returned to the factory for evaluation. If the unit is found to be defective upon examination by J-KEM, it will be repaired or replaced at no charge. However, this WARRANTY is VOID if the unit shows evidence of having been tampered with or shows evidence of being damaged as a result of excessive current, heat, moisture, vibration, corrosive materials, or misuse. This WARRANTY is VOID if devices other than those specified in Section 3.2 are powered by the controller. Components which wear or are damaged by misuse are not warranted. This includes contact points, fuses and solid state relays.

THERE ARE NO WARRANTIES EXCEPT AS STATED HEREIN. THERE ARE NO OTHER WARRANTIES, EXPRESSED OR IMPLIED, INCLUDING BUT NOT LIMITED TO THE IMPLIED WARRANTIES OF MERCHANTABILITY AND OF FITNESS FOR A PARTICULAR PURPOSE. IN NO EVENT SHALL J-KEM SCIENTIFIC, INC. BE LIABLE FOR CONSEQUENTIAL, INCIDENTAL OR SPECIAL DAMAGES. THE BUYER'S SOLE REMEDY FOR ANY BREACH OF THIS AGREEMENT BY J-KEM SCIENTIFIC, INC. OR ANY BREACH OF ANY WARRANTY BY J-KEM SCIENTIFIC, INC. SHALL NOT EXCEED THE PURCHASE PRICE PAID BY THE PURCHASER TO J-KEM SCIENTIFIC, INC. FOR THE UNIT OR UNITS OF EQUIPMENT DIRECTLY AFFECTED BY SUCH BREACH.

Service

J-KEM Scientific maintains its own service facility and technical staff to service all parts of the controller, usually in 24 hours. For service, contact:

J-KEM Scientific, Inc.
858 Hodiament Ave.
St. Louis, MO 63112
USA
(314) 863-5536
fax (314) 863-6070
E-Mail: jkem911@jkem.com
Internet on-line catalog: www:jkem.com

This manual contains parameters specific to this temperature controller.
When calling with a technical question, please have the controller's serial number available.

You've purchased the most versatile controller available to the research community. We're confident it can regulate ANY heating/cooling situation you'll ever encounter. If the information in this manual isn't adequate for your application, contact our Engineering Department for assistance.

– With J-KEM's patented Microtune circuitry –

INDEX

<u>SECTION</u>	<u>PAGE</u>
1. QUICK OPERATING INSTRUCTIONS	4
KEM-NET DATA LOGGING AND CONTROL SOFTWARE	5
2. ADJUSTING THE CONTROLLER FOR STABLE CONTROL WITH DIFFERENT HEATERS	6
2.1 What is Tuning	6
2.2 Autotuning Procedure	7
2.3 Tuning for Heating Mantles: A Special Case	9
2.4 Sensor Placement	9
3. OPERATIONS GUIDE	10
3.1 Front Panel Description	10
3.2 Heater Restrictions	11
3.3 Ramp-to-Setpoint & Soak Feature	11
3.4 Over Temperature Protection Circuit	14
3.5 Timer Controls	15
3.6 Output Power Level	18
3.7 Temperature Sensor Input	20
3.8 Affect of Power Setting on Heating Profile	20
3.9 Do's and Don'ts When Using Your Controller	21
3.10 Resetting the Controller for use With Heating Mantles	22
3.11 Changing the Temperature Display Resolution	22
3.12 Changing Between PID and ON/OFF Operating Modes	23
3.13 Optional Safety and Automation Features	24
3.14 Troubleshooting	24
4. APPLICATION NOTES	26
4.1 Theory of How the Controller Works – Simply	26
4.2 Controlling a Heating Mantle Temperature Directly	27
4.3 Automatic Storage of Min/Max Temperatures	28
4.4 How to Set Up a Reaction With Your Temperature Controller.	29
APPENDIX	33
I. Using the Controller With an Oil Bath (Application Note 1)	33
II. Safety Considerations and Accurate Temperature Control	34
III. The Effect of Power Level and Tuning on Control Stability	36
IV. Resetting the Controller to Original Factory Settings	39

<u>WARNING:</u> Adhere to the restrictions of SECTION 3.2 . Failure to do so may create a significant safety hazard and will void the warranty.

Section 1: Quick Operating Instructions

The five steps below are the basics of using your temperature controller. It's recommended that new users unfamiliar with process controllers read the entire manual carefully. **The controller is preprogrammed for use with heating mantles fitted to round bottomed flasks running "typical" organic reactions (i.e., non-polymeric reactions in solvents such as THF, toluene, DMF, etc.).**

For a primer on how to set up a reaction with your temperature controller: See Section 4.4

To use heaters other than heating mantles: See Section 2.

Do not use the controller to heat oil baths: See Section 3.2 & Appendix I.

For polymer synthesis, atypical, expensive, or safety critical reactions: See Appendix II.

1 Place the thermocouple in the solution being heated. Place at least the first 1/4" of the thermocouple directly in the solution being heated. Thermocouples can be bent without harming them. If you're heating a corrosive liquid, use a Teflon coated thermocouple. If you are heating a sealed reaction, see Section 4.2.

2 Select the Channel to Operate. The Gemini has two completely independent controllers in a single cabinet. Both channels provide the same type of temperature control, the only difference is that Channel 1 has a 100 hour timer to turn heating On/Off at a user set time, and Channel 2 does not. If Channel 2 is being used, only steps 3 & 4 need to be followed, if Channel 1 is being used, then steps 3 & 4 must be followed, but also step 5, where the timer controls are set. For more information on using the timer controls, see Section 3.5.

3 Set the power level switch to the volume of solution being heated

(not the size of the flask being used). Adjust the power level for the channel being used. The power level switch can be thought of as a solid state variac. Volume ranges are printed above this switch as a guide to select the correct power level since it's easier to guess the volume being heated than the appropriate "percent power" to apply to a heater. 'Heat Off' turns off the heater so the controller displays temperature only. Section 3.6 should be read by all new users.

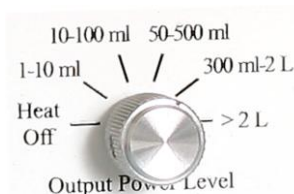

A power setting of.....	is equivalent to a variac setting of:
1-10 ml	3%
10-100 ml	10%
50-500 ml	25%
300 ml - 2 L	50%
> 2 L	100%

TIP: Because the power switch acts like a variac, if the reaction is heating too slowly or you need more power (e.g., heating to high temperatures), give the heater more power by turning the power level up one setting. If the

reaction needs less power than normal (e.g., heating to low temperatures (<60° C) or the temperature overshoots the set point excessively, turn the power down one setting. **DO NOT** set the power switch on a setting too high initially to heat the reaction quickly and then lower it to the correct setting, this degrades heating performance.

4 Enter the setpoint (i.e., the desired temperature). Hold in the * button and simultaneously press the ↑ key to increase or the ↓ key to decrease the setpoint. The setpoint can be seen at anytime by holding in the j button, the setpoint appears as a blinking number in the display.

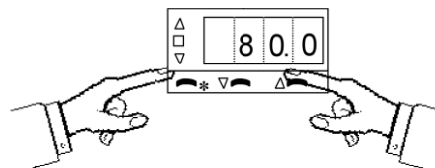

5 Set the timer.

For Channel 1 Only,
The timer turns the heating outlet OFF or ON depending on the position of the timer switch and whether any time is present in the display



The timer controls only affect the operation of Channel 1. The red LED display window always shows the effect that the timer controls have on the state of Channel 1's output power. When the controller is first turned on, the timer window displays 'Off' to indicate the timer controls have disabled output power. To set the timer controls so that they will allow power to be applied to the outlet, quickly push in the timer function knob once. This will change the timer status to 'On'. For additional information on the operation of the timer, see Section 3.5.

KEM-Net Data Logging and Control Software

The USB port on the back panel of the controller is an interface to J-KEM's KEM-Net Software. KEM-Net is free and can be downloaded from J-KEM's web site at www.jkem.com.

	<p>KEM-Net provides remote control of up to 8 controllers, graphical presentations of each digital meter and time & temperature plots. Highlights of KEM-Net include:</p> <ul style="list-style-type: none">* GLP and GMP compliant data logging* Runs a 12 step temperature ramp* Logging of Time and Temperature* Logging of % Power for Exo and Endotherm detection* Program KEM-IO Actions (Section 3.10)* Over- & Under-temperature alarm functions.
---	--

KEM-Net also includes a virtual comm port driver that provides a simple ASCII interface to operate and data log the controller from LabView or other software packages.

New Features:

GMP compliant data logging
Exo and Endotherm monitoring

KEM-IO Remote Control of Laboratory Equipment based on Time and Temperature

KEM-IO is an optional feature that allows the controller to respond to inputs from instruments, like a vacuum sensor or a hood door switch, and also to control instruments, like stirrers and chillers based on reaction temperature. KEM-IO automates programs as simple as:

Heat my reaction to 80° C, then turn on my peristaltic pump to add reagents.

or as sophisticated as:

Turn on my stirrer, then ramp my reaction from 25° C to 100° C if 45 minutes, hold for 2 hours, then turn off heating. When the reaction cools to 50° C, turn off the stirrer. If at any point the reaction exotherms and heats above 110 °C, turn on my chiller and keep it on until I manually reset the system.

Contact J-KEM for additional information.

Section 2: Adjusting The Controller For Stable Control With Different Heaters

The Gemini controller has 2 completely independent temperature controllers in one cabinet. It's important to remember that changes made to Channel 1 have no effect on Channel 2 and visa-versa. Each channel must be tuned and adjusted separately.

2.1 What is Tuning. The controller's most powerful feature is its ability to regulate virtually any heater with stable temperature control. To achieve stable control, the controller must 1) be set to the correct power level (see Section 3.6) and, 2) be *tuned* to the heater being used. Tuning is the process that matches the control characteristics of the controller to the heating characteristics of the heater. The controller is said to be tuned to the heater when its memory is programmed with values describing how fast the heater warms up, cools off, and how efficiently it transfers heat. For example, consider the difference between a heat lamp and a hot plate. When electricity is applied to a heat lamp it begins to heat instantaneously, and when it's turned off it stops heating instantaneously. In contrast, a hot plate takes several minutes to begin heating when electricity is applied and even longer to stop heating when electricity is turned off. Your controller can regulate both a heat lamp and a hot plate to 0.1° C. But, to do this it must be programmed with the time constants describing how fast the heater heats and cools when electricity turns ON or OFF. These time constants are called the *tuning parameters*.

Every type of heater has its own unique set of tuning parameters. For the controller to heat with stability, it must have programmed with the tuning parameters for the heater currently being used. Prior to shipment, tuning parameters were programmed into the controller that maximize heating performance for laboratory heating mantles since these are the most common heaters used in research. Tuning is regulated by 5 of the temperature meter's user programmable functions. The correct value for these 5 functions can be calculated and loaded manually, or the controller can do it automatically with its autotune feature.

When Should the Controller be Tuned? If the controller is tuned to one type of heater, heating mantles for example, any size heating mantle can be used without the need to retune. When changing from heating mantles to a different type of heater, an oven for example, the controller should be tuned with values describing the oven's heating characteristics. The effect of tuning is seen below. When the controller is tuned for heating mantles, using it with any size heating mantle yields stable temperature control (Plot 1), but poor control results when the same tuning parameters are used with an oven (Plot 2, Curve 1). However, after tuning the controller to the oven, stable temperature control results (Plot 2, Curve 2).

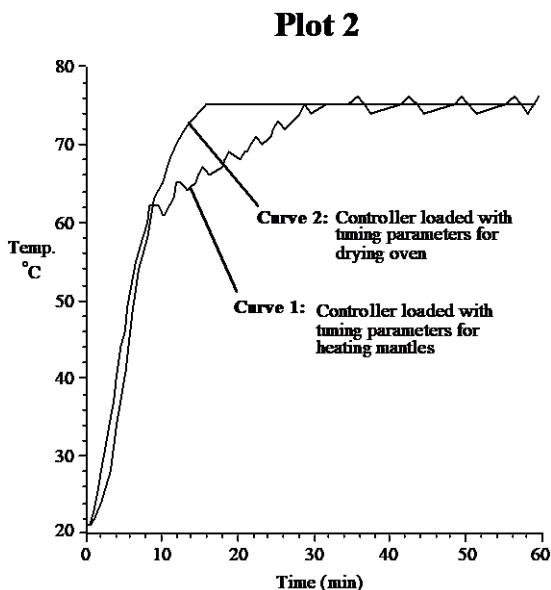
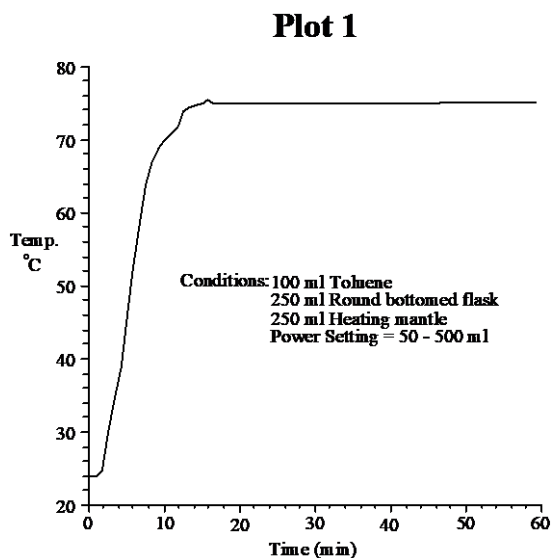

It's important to understand that this controller isn't a simple ON/OFF type controller (i.e. ON when below the set point, OFF when above [though it can be made to work this way, see Section 3.12]). Rather it's a *predictive* controller. Based on the shape (slope) of the heating curve, the controller predicts (calculates) the percent of power to apply to the heater now to control the shape of the heating curve minutes in advance. The importance of the tuning parameters is that they are constants in the equation the temperature meter uses to perform its predictive calculations. If the temperature meter is programmed with tuning parameters that incorrectly describe the heater being used, poor temperature control will result. But, when the correct values are loaded, temperature regulation of $\pm 0.1^\circ$ is typically achieved.

Manual Tuning. Manual tuning is when the values of the 5 tuning parameters are determined manually then entered into the temperature meter via the push buttons on the front of the controller. Experienced users might prefer to manually tune the controller since this allows customization of the heating process.

Autotune. Autotune is a feature built into the temperature meter that automatically calculates the tuning parameters (i.e. delay times, heating efficiency, etc.) for any type of heater. After the autotune procedure is complete and the tuning parameters are determined, the controller loads them into its memory for current and future use. Heating mantles are a special case and are covered in a separate paragraph (Section 2.3).

2.2 Autotuning Procedure.

This procedure is not recommended for heating mantles (see Section 2.3). Perform this procedure only on the controller channel in use.

1. Set the equipment up in the exact configuration it will be used. For example, to tune to a vacuum oven, place the thermocouple in the room temperature oven and plug the oven into the controller. If the oven (or heater) has its own thermostat or power control, turn both as high as they'll go.
2. Set the controller to the appropriate power level (see Section 3.6). If tuning Channel 1, make sure the timer switch is set so that heating is on (see Section 3.5). Turn the controller and heater on, then enter the desired set point temperature. If the set point isn't at least 30° C above ambient, skip this procedure and go to the next procedure, "Autotuning the Controller for Very Fine Control"
3. Press and hold in both the \uparrow and \downarrow buttons (for 3 seconds) on the front of the temperature meter until the word "tunE" appears in the display then release both buttons.
4. Press the \uparrow button (5 times) until "CyC.t" appears in the display (if you go past this setting, press the \downarrow button until you get back to it).
5. First, hold in the '*' button, while holding in the '*' button press the \downarrow button. Continue to hold both buttons in until the display reads "A --", or "A ###" where "###" is some number.
6. Release the '*' button and press the \downarrow button until "tunE" once again appears in the display.
7. Press and hold the '*' button and "tunE" will change to "off" to indicate that autotune is currently off.
8. While holding in the '*' button, press the \uparrow button to change the display to "on", then release both buttons.
9. Press and hold both the \uparrow and \downarrow buttons (for 3 seconds) until the temperature appears in the display. The controller is now in its autotune mode. While in autotune the display alternates between "tunE" (for autotune) and the process temperature. When the autotune sequence is done (this may take in excess of an hour) the controller stops displaying "tunE" and only displays the process temperature. [To abort autotune manually, repeat steps 3, 8 and 9 except in step 8 press the \downarrow button until "off" is displayed].

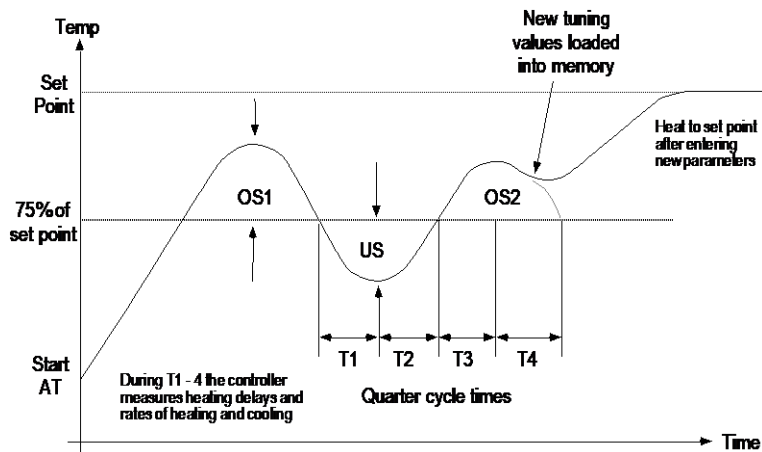

The autotune sequence.

During autotune the controller heats to 75% of the set point temperature where it oscillates for several cycles before loading the new tuning parameters. After the tuning parameters are loaded it heats to the set point temperature. Tuning below the set point prevents any damage that might occur from overheating.

Autotuning the Controller for Very Fine Control.

This procedure is not recommended for heating mantles (see Section 2.3).

In the majority of cases, the procedure above results in stable temperature control with any heater. A second version of the autotune routine is available and can be used when the heater is already at or close to the set point, is being tuned at a temperature close to room temperature, or for very fine control in demanding situations. If stable temperature control doesn't result after performing the first autotune routine, the procedure below should be performed. Before performing the 'fine tune' autotune procedure, the 'regular' autotune procedure that precedes this should normally be performed.

1. Set the equipment up in the exact configuration it will be used. If the heater has its own thermostat or power controls, turn both as high as they'll go. With this procedure it's not necessary for the equipment to start at room temperature. This procedure can be performed at any time and any temperature.
2. Set the controller to the appropriate power level (see Section 3.6). If tuning Channel 1, make sure the timer switch is set so that heating is on (see Section 3.5). Turn the controller and heater on, then enter the desired set point temperature.
3. Press and hold in both the \uparrow and \downarrow buttons (for 3 seconds) on the front of the temperature meter until the word "tunE" appears in the display then release both buttons.
4. Press the \uparrow button (5 times) until "CyC.t" appears in the display (if you go past this setting, press the \downarrow button until you get back to it).
5. First, hold in the '*' button, while holding in the '*' button press the \downarrow button. Continue to hold both buttons in until the display reads "A --", or "A ##" where "##" is some number.
6. Release the '*' button and press the \downarrow button until "tunE" once again appears in the display.
7. Press and hold the '*' button and "tunE" will change to "off" to indicate that autotune is currently off.
8. While holding in the '*' button, press the \uparrow button to change the display to "At.SP", then release both buttons.
9. Press and hold both the \uparrow and \downarrow buttons (\approx 3 seconds) until the temperature appears in the display. The controller is now in its autotune mode. While in autotune the display alternates between "tunE" (for autotune) and the process temperature. When the autotune sequence is done (this may take in excess of an hour) the controller stops displaying "tunE" and only displays the process temperature. [To abort autotune manually, repeat steps 3, 8 and 9 except in step 8 press the \downarrow button until "off" is displayed].

Autotune Errors. The autotune routine can fail for several reasons. If it fails, the controller displays the error message “**tunE**” “**FAiL**”. To remove this message turn the controller off for 10 seconds. Try the procedure titled “Autotuning the Controller for Very Fine Control” above. If autotune fails again, call and discuss your application with one of our engineers. A common problem when tuning at high temperatures or with large volumes is for the heater to be underpowered. A more powerful heater may be needed (contact J-KEM for assistance).

2.3 Tuning for Heating Mantles: A Special Case. This section gives special consideration to heating mantles, since they’re the most commonly used heaters in research. Every heating mantle size has its own optimum set of tuning parameters and if you wanted, the controller could be tuned (or autotuned) every time a different size was used. However, this is cumbersome and is also unnecessary. Factory tests show that there’s one set of tuning parameters that delivers good performance for all heating mantle sizes. These tuning parameters were loaded into the controller at the factory prior to your receiving it. If you’re using a heating mantle and none of the parameters have been changed or the controller hasn’t been autotuned since you’ve received it, you’re ready to go. If the tuning parameters have been changed or the controller has been autotuned and you want to go back to using heating mantles, J-KEM recommends that the tuning parameters for heating mantles be loaded manually (i.e., don’t autotune to the heating mantle) by following the step-by-step instructions given in Procedure 4 of Section 3.10.

2.4 Sensor Placement. Placement of the sensor is basically common sense. The sensor should be positioned to sense the average temperature of the medium being heated. That means the thermocouple should be shielded from direct exposure to the heater but not so distant that a rise in temperature isn’t sensed by the controller within a reasonable period of time. Several examples follow that show the type of consideration that should be given to sensor placement.



Use With:	
Solutions	Place the sensor <u>in</u> the solution. Stir vigorously so that heat is homogeneously mixed throughout the solution.
HPLC column heated with a heating tape	Tape a thin wire thermocouple directly to the HPLC column. Place several layers of paper over the thermocouple to insulate it from the heating tape (the thermocouple should sense the <u>column</u> temperature, not the heater temperature). Wrap the HPLC column completely with heating tape.
Oven	The thermocouple needs to be shielded from transient hot and cold air currents. Don’t place the thermocouple near the heating coil or an air vent. A small thermocouple (1/16” or 1/8” thermocouple) that responds rapidly to changes in air temperature is better than a larger one.

Section 3: Operations Guide

3.1 Front Panel Description.

The Gemini controller has two independent temperature controllers in a single cabinet. The two controllers are labeled Channel 1 and Channel 2. The controls for Channel 1 have no effect on the operation of Channel 2 and visa versa.

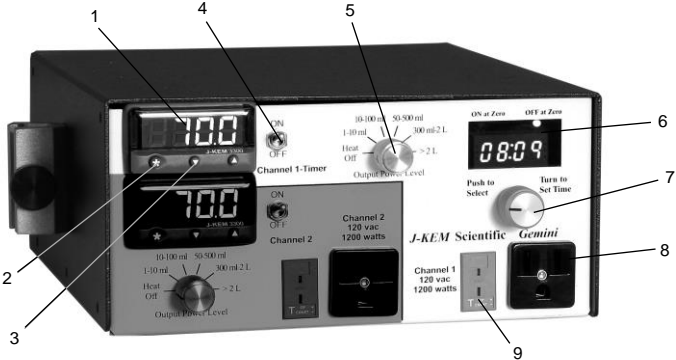
J-KEM highly recommends that all users read Section 4.4 - *How to Set Up a Reaction with J-KEM Scientific's Digital Temperature Controller* prior to using the controller for the first time.

<h3 style="text-align: center;">Controls for Channel One</h3> 	<h3 style="text-align: center;">Controls for Channel Two</h3> 
<ol style="list-style-type: none"> 1. Channel 1 Temperature Display. Shows the temperature of the process connected to Channel 1 as the default display. Shows the setpoint temperature (i.e. desired temperature) when the '*' button is held in. 2. Control Key When pressed, the display shows the set point temperature. To decrease or increase the set point, press the ↑ key (3) or ↓ key (3), while simultaneously pressing the control key. The set point appears as a blinking number in the display. 3. Down/Up Key Lowers or raises the setpoint when '*' button (2) is simultaneously pressed. 4. On/Off Switch. WARNING: Due to the nature of solid state relays, a small amount of output power (7.5 mA @ 120 VAC; 0.9 watts) is present at outlet (8) even when the controller is turned off. Take appropriate precautions to avoid electrical shock. 5. Channel 1 Power Level. This knob is the interface to J-KEM's patented power control computer which limits the maximum power delivered to the heater. See Sections 3.6 and 4.1. 6. Timer Display. Indicates the status of the timer. See Section 3.5 for timer operation instructions. 7. Timer Mode Selector. Sets the operating mode of the timer. See Section 3.5 for timer operation instructions. 8. Channel 1 Power Outlet. Plug only 120 VAC devices into this outlet (see Section 3.2). 9. Channel 1 Temperature Sensor Input. Use the same type of sensor probe as the sensor plug installed on the controller (see Section 3.7). The correct sensor type will have the same color plug as the input (9) on the front of the controller. 	<ol style="list-style-type: none"> 10. Channel 2 Temperature Display. Shows the temperature of the process connected to Channel 2 as the default display. Shows the setpoint temperature (i.e. desired temperature) when '*' button is held in. 11. Control Key When pressed, the display shows the set point temperature. To decrease or increase the set point, press the ↑ key (12) or ↓ key (12), while simultaneously pressing the control key. The set point appears as a blinking number in the display. 12. Down/Up Key Lowers or raises the setpoint when '*' button (11) is simultaneously pressed. 13. Channel 2 Power Level. This knob is the interface to J-KEM's patented power control computer which limits the maximum power delivered to the heater. See Sections 3.6 and 4.1. 14. On/Off Switch. WARNING: Due to the nature of solid state relays, a small amount of output power (7.5 mA @ 120 VAC; 0.9 watts) is present at outlet (16) even when the controller is turned off. Take appropriate precautions to avoid electrical shock. 15. Channel 2 Temperature Sensor Input. Use the same type of sensor probe as the sensor plug installed on the controller (see Section 3.7). The correct sensor type will have the same color plug as the input (15) on the front of the controller. 16. Channel 2 Power Outlet. Plug only 120 VAC devices into this outlet (see Section 3.2).

3.2 Heater Restrictions. Each channel of the controller can individually deliver up to 10 amps of current at 120 VAC, but the combined total current from Channels 1 & 2 can not exceed 15 amps. These current ratings are limited to resistive loads (heating mantles, hot plates, ovens, etc.). **Use only resistive loads that are safely operated at 120 VAC and require less than 10 amps or damage to the controller and a safety hazard may result.**

- **Do not plug oil baths into your controller. Oil baths are not 120 VAC devices and become a fire hazard unless properly connected to the controller.** (See Appendix for an application note describing the use of oil baths with this controller). Ask about J-KEM’s new 400 series controllers for use with oil baths.

3.3 Ramp-to-Setpoint & Soak Feature. A new feature of J-KEM’s controllers called ‘Ramp-To-Setpoint’ allows you to enter a specific heating rate (e.g., heat to 120° C at a rate of 5° C/Hour), a second feature called ‘Soak’ then lets you specify how long to stay at that temperature before turning off.

Examples of Program Ramps

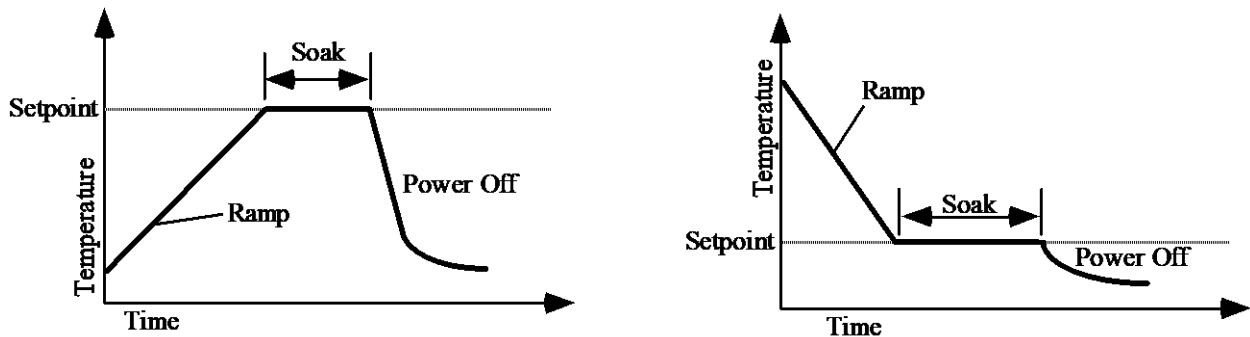

The controller is shipped with the Ramp-to-Setpoint feature OFF, the user must specifically turn Ramp-to-Setpoint ON. When Ramp-to-Setpoint is OFF, the controller heats to the entered setpoint at the fastest rate possible. When Ramp-to-Setpoint is ON, the controller heats at the user entered ramp rate. The Ramp-to-Setpoint feature and its associated parameters are turned on and set in the controller’s programming mode. The parameters of importance are:

SPrr SetPoint Ramp Rate. Allowable Values: 0 to 9990 deg/Hr.

This specifies the desired rate of heating (cooling). Note, this parameter specifies the *desired* rate of heating (cooling), but in cases of extremely high ramp rates the reaction will not actually heat faster than the power of the heater will allow.

SPrn SetPoint Ramp Run. Allowable Values: ON, OFF, Hold

This parameter turns the Ramp-to-Setpoint feature ON or OFF. During an active run, if this parameter is set to ‘Hold’, the setpoint ramp stops and *holds* at its’ current value. This continues until the parameter is set to ON or OFF. When set to OFF, the values in SetPoint Ramp Rate and Soak Time are ignored.

SoAK Soak Time. Allowable Values: “- -”, 0 to 1440 min.

This specifies the amount of time to *soak* at the setpoint after the setpoint temperature ramp is complete. A setting of “- -” causes the controller to remain at the final setpoint indefinitely. A numeric value causes the controller to stay at the setpoint for the entered time and then turn power to the heater off after the time expires.

Important Points to Know

1. While the Ramp-to-Setpoint feature is activated, the display alternates between the current reaction temperature and the word “**SPr**” to indicate that a “SetPoint Ramp” is active.
2. If this controller is equipped with a digital 100-hour timer, the digital timer and the Ramp-to-Setpoint feature are completely independent of each other. For example, if the digital timer is set to turn heating OFF after 5 hours, heating **is** turned off even if a ramp step is in progress. Likewise, if a Soak time turns heating off after 3 hours and the digital timer is set to turn heating off after 10 hours, the digital timer has no effect since the expired Soak time already has turned heating off.
3. Once the Ramp-to-Setpoint feature is activated in programming mode, it remains on until it’s deactivated in programming mode. The Ramp-to-Setpoint feature remains activated even when power is turned off, and then turned back on.
4. Setting a ramp rate in the digital controller does not guarantee that the reaction temperature itself will ramp at the entered value, since the rate of heating is dependent on the power of the heater. Setting a ramp rate in the controller only guarantees that the controller’s setpoint will be changed at the entered rate. For the reaction temperature to increase temperature at the specified rate, the heater must have sufficient power to heat at the entered rate. This is a critically important point, the user must understand that the electronic setpoint in the controller will ramp at the entered rate, but the controller cannot *force* a heater to heat a reaction faster than it’s capable of doing. For example, see the plots below.

Plot 1 – This plot uses a heating mantle to ramp reaction temperature from 20 to 80C in 60 minutes. The reaction temperature closely matches the setpoint of the controller because the heating mantle has enough power to heat a typical reaction at the modest heating rate of 1 degree per minute.

Plot 2 – In this example, the ramp rate is set to 600 C/ hour, or 10 C per minute. The controller ramps the setpoint at the requested rate, but the reaction temperature does not match the ramp, because the heater does not have enough power to heat the reaction at such a high rate. The point is, if the heater only has enough power to heat the reaction at 5 C/min, then setting a ramp rate of 10 C/min will not work. The digital meter in the controller will ramp at 10 C/min, but the heater, using its maximum power, will still only heat at 5 C/min. The power of the heater, in most cases, is the limiting factor when ramping. The only solution is to 1) use a more powerful heater, or 2) lower the ramp rate to a value that does not exceed the heaters maximum heating rate.

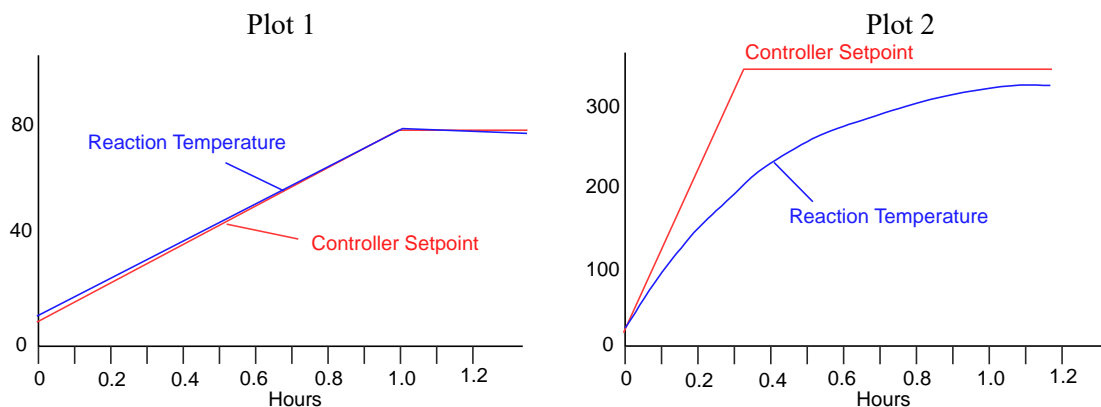

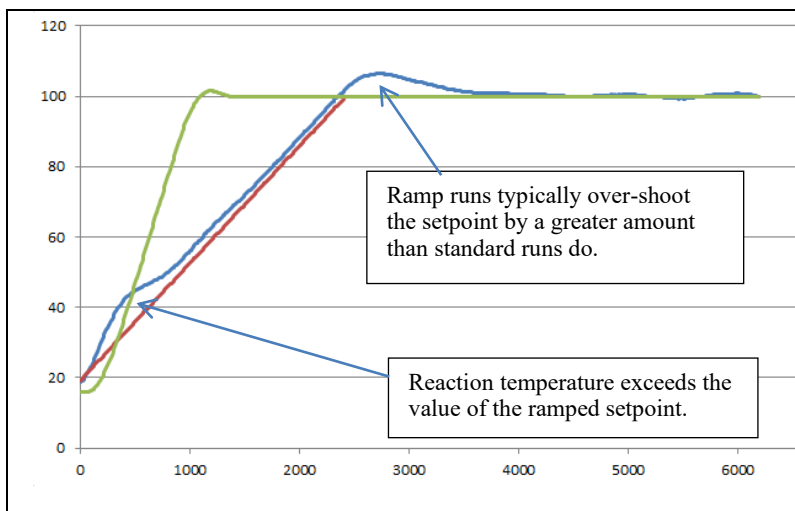

This plot shows actual data. The green line is the temperature profile when ramping is not used and the reaction heats to the setpoint as normal. The red and blue lines are the result of a ramp run. The red line is the setpoint being ramped at a rate of 2 C/min. The blue line is the reaction temperature that results from this ramp. Two features of this plot are characteristics of ramp runs. 1) At the start of a run, the reaction temperature almost always exceeds the temperature of the ramped setpoint, and 2) ramp runs overshoot the final setpoint value by 4-5 C.

Cooling Ramps

Cooling ramps, when the reaction temperature is allowed to cool at a user set rate can also be created. What's important to remember about cooling ramps, is that your controller has no capability to actively cool a reaction, the only way for a reaction to cool is to radiate heat to the atmosphere. So, a researcher must never set a cooling rate faster than the reaction can naturally cool.

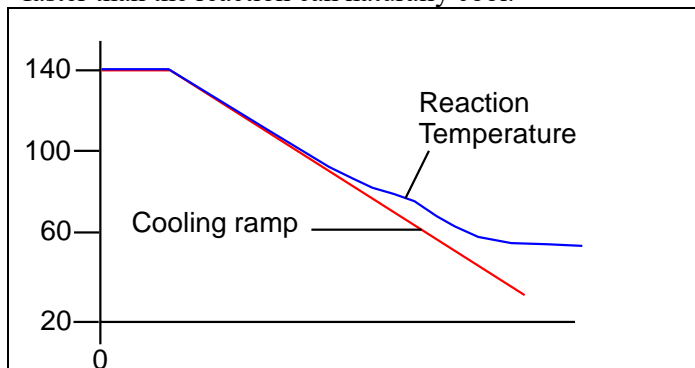

Just as in the case of heating ramps, the meters ramping function must be turned on and a ramp rate entered. In the case of the plot at the left, the reaction was at 140 C, and then the setpoint is changed to 30 C. The reaction initially cools (loses heat to the air around it) according to the entered ramp. Towards the end of ramp the requested rate of cooling is faster than the rate that the flask can naturally cool at, and so the reaction's rate of cooling becomes less than the entered setpoints rate of cooling.

Cooling ramps can be very helpful in processes like crystallizations where cooling ramps tend to be very slow, in this case, the solution temperature often matches the requested cooling rate very closely.

Below are two plots of more complicated ramp programs. The first plot shows results that might be expected from a **standard** heating mantle and the free version of KEM-Net. The power control computer (the knob on the front of the controller with volumes associated with it) is independent of the KEM-Net program. In order for the reaction to reach temperatures >150C, the power setting must be set to “> 2L”. This creates a problem at low temperatures, as can be seen during the portion of the ramp heating from 25 – 50C. The reaction has a large overshoot due to applying 100% power to the heating mantle. The standard version of KEM-Net does not allow the user to enter different power levels during the setup of the ramp program. Standard power heating mantles generally can heat to a maximum temperature of 250-270 C, and so the plot shows slow heating when going from 150 – 250C, and then not being able to heat above 270 C.

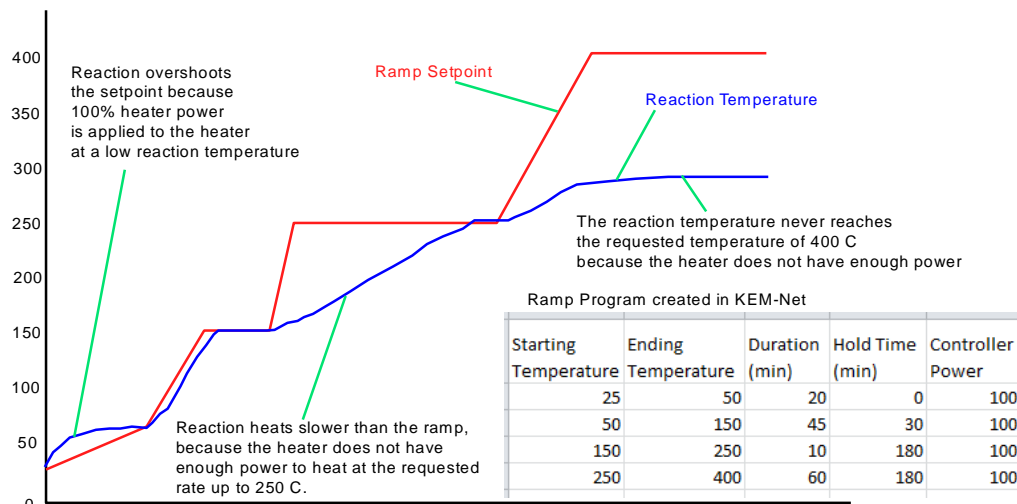

This plot shows the results that might be expected when using a **high power** heating mantle and the ProMode version of KEM-Net. J-KEM offers both standard and high power heating mantles, the standard version is the more common cloth-style heating mantle. The ProMode version of KEM-Net allows the user to create a ramp program, and also to enter the percent power that the controller should use during the segment of the ramp program. For example, during the first step when heating from 25 to 50C, the power level sent to the meter is 15% of maximum power, which is appropriate for temperatures close to room temperature. Using 15% power, rather than 100% power in the top plot results in a better ramp profile for this step. Also, using the high power heating mantle provides enough power that the solution can be heated to the desired 400 C final temperature.

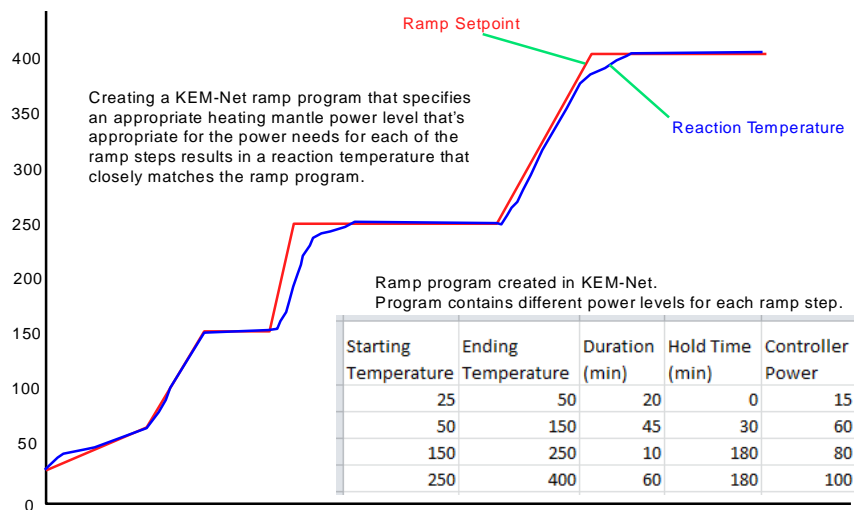

Activating & Programming the Ramp-to-Setpoint Feature

tunE bAnd int.t der.t dAC CyC.t oFSt SP.Lk **SPrr** **SPrn** **Soak** SEt.2 bnd.2 CyC.2

This is the order of controller parameters on Level 1 of the controller, when the controller is placed into programming mode (Step 1) below.

1.	<p>Before starting a new ramp, the controller must have the ramping feature turned off. Verify that the ramping feature is turned off by entering programming mode and checking verifying this before continuing.</p> <p>To enter programming mode, press and hold in both the ▲ and ▼ keys on the front of the temperature meter until the word “tunE” appears in the display, then release both keys.</p> <p>Now press the ▲ key (9 times) until the word “SPrr” appears in the display, then release all keys. The display on the controller will alternate between “SPrr” and the word ON or OFF. If the word OFF is displayed, then exit programming mode and proceed to Step 2. If the word ON is displayed, then hold in the ‘*’ key and press the ▼ key once to change the display from ON to OFF, then release all keys. To exit programming mode, press and hold in both the ▲ and ▼ keys until the temperature appears in the display, then release both keys.</p>
2.	Note the current reaction temperature displayed by the controller. Enter this temperature into the controller as the new setpoint. For example, if the current reaction temperature is 22.5 C, then set the controller’s setpoint to 22.5 C.
3.	Press and hold in both the ▲ and ▼ keys on the front of the temperature meter until the word “tunE” appears in the display, then release both keys.
4.	<p>Press the ▲ key (8 times) until the word “SPrr” appears in the display.</p> <p>This is where the ramp rate in units of degrees/hour is entered. First hold in the ‘*’ key, then while holding in the *’ key press the ▼ or ▲ key until the desired ramp rate appears in the display, then let go of all the keys. Units are in degrees/hour, so if you want a ramp rate of 2C/min, then enter a value of 120.</p>
5.	<p>Press the ▲ key once and the word “SPrn” will appear in the display.</p> <p>This function turns the ramping feature ON or OFF. First hold in the ‘*’ key, then while holding in the *’ key press the ▼ or ▲ key until the display shows ON (to start a ramp) or OFF (to terminate a ramp), then let go of all the keys.</p>
6.	<p>Press the ▲ key once and the word “Soak” will appear in the display.</p> <p>This is where the soak time is entered in units of minutes. A soak time of ‘--’ means to ‘soak forever’ (this setting is one below ‘0’). First hold in the ‘*’ key, then while holding in the *’ key press the ▼ or ▲ key until the desired time appears in the display, then let go of all the keys. If a soak time is set, the controller display will alternate between showing the current reaction temperature and the word “StoP” when the soak time has expired to indicate that power has been turned off.</p>
7.	To exit programming mode, press and hold in both the ▼ and ▲ keys until the temperature appears in the display, then release both keys.
8.	<p>Temperature ramping is now enabled in the controller. Any time a new setpoint is entered into the controller, the controller ramps from the current displayed temperature to the new setpoint at the rate entered.</p> <p>For example, if your controller is currently displaying the sensed temperature at 25.0 C, then entering a new setpoint of 100.0C, will cause the controller to ramp from 25 to 100C at the ramp rate entered in step 4. The controller can ramp to setpoints higher than the current temperature (heating ramp) and to setpoints lower than the current temperature (cooling ramp).</p>

Deactivating the Ramp-to-Setpoint Feature

1.	Press and hold in both the ▲ and ▼ keys on the front of the temperature meter until the word “tunE” appears in the display, then release both keys.
2.	<p>Press the ▲ key (9 times) until the word “SPrn” appears in the display.</p> <p>This function turns the ramping feature ON and OFF. First hold in the ‘*’ key, then while holding in the *’ key press the ▼ or ▲ key until OFF appears in the display, then let go of all the keys.</p>
3.	To exit programming mode, press and hold in both the ▲ and ▼ keys until the temperature appears in the display, then release both keys.

3.4 Over Temperature Protection Circuit.

NOTE: The controller is shipped with the Over Temperature Protection Circuit **DISABLED**. To activate this circuit for either or both channels, follow Procedure 3 below.

Both channels of the Gemini are equipped with over temperature protection circuits. This circuit turns off heating and sounds an audible alarm if the process temperature for Channel 1 and/or Channel 2 exceeds the set point by 5 degrees. The high temperature limit (i.e. the limit that must be exceeded to trigger this circuit) is factory set to 5 degrees for both channels, but can be changed or enabled or disabled as outlined in the procedures below. The over temperature protection circuit for Channels 1 & 2 are independent of each other. A temperature limit entered into the temperature meter controlling Channel 1 has no affect on Channel 2 and visa versa.

To Change the Number of Degrees that the Reaction Temperature Must

Procedure 1. Exceed the Set Point to Trigger the Over Temperature Alarm, Perform this Procedure.

1.	Press and hold in both the ↑ and ↓ keys on the front of the temperature meter for the Channel you want to change until the word “tunE” appears in the display, then release both keys.
2.	Press the ↑ key until “SEt.2” is showing in the display. First hold in the ‘*’ key, while holding in the ‘*’ key press the ↑ or ↓ keys until the desired temperature limit is showing in the display, then let go of all the keys.
3.	Press and hold in both the ↑ and ↓ keys until the temperature is showing again.

Procedure 2. To Permanently Disable the Over Temperature Circuit, Perform this Procedure.

1.	Press and hold in both the ↑ and ↓ keys on the front of the temperature meter for the Channel you want to change until the word “tunE” appears in the display, then release both keys.
2.	Press the ↓ key until “LEVL” is showing in the display.
3.	Hold in the ‘*’ key, while holding in the ‘*’ key press the ↑ key until “2” is showing in the display, then let go of all the keys.
4.	Press the ↑ key until “SP2.A” is showing in the display.
5.	Hold in the ‘*’ key, while holding in the ‘*’ key press the ↓ key until “nonE” is showing in the display, then let go of all the keys.
6.	Press the ↓ key until “LEVL” is showing in the display.
7.	Hold in the ‘*’ key, while holding in the ‘*’ key press the ↑ key until “3” is showing in the display, then let go of all the keys.
8.	Press the ↑ key until “rEU.d” is showing in the display.
9.	Hold in the ‘*’ key, while holding in the ‘*’ key press the ↑ key until “1r.2d” is showing in the display, then let go of all the keys.
10.	Press and hold in both the ↑ and ↓ keys until the temperature is showing again. When you do this, the alarm will sound.
11.	Increase the set point by any amount by first holding in the ‘*’ key, then while holding in the ‘*’ key press the ↑ key.

Procedure 3. To Enable the Over Temperature Protection Circuit, Perform this Procedure.

1.	Press and hold in both the ↑ and ↓ keys on the front of the temperature meter for the Channel you want to change until the word “tunE” appears in the display, then release both keys.
2.	Press the ↓ key until “LEVL” is showing in the display.
3.	Hold in the ‘*’ key, while holding in the ‘*’ key press the ↑ key until “2” is showing in the display, then let go of all the keys.
4.	Press the ↑ key until “SP2.A” is showing in the display.
5.	Hold in the ‘*’ key, while holding in the ‘*’ key press the ↑ key until “dU.hi” is showing in the display, then let go of all the keys.
6.	Press the ↓ key until “LEVL” is showing in the display.
7.	Hold in the ‘*’ key, while holding in the ‘*’ key press the ↑ key until “3” is showing in the display, then let go of all the keys.
8.	Press the ↑ key until “rEU.d” is showing in the display.
9.	Hold in the ‘*’ key, while holding in the ‘*’ key press the ↑ key until “1r.2r” is showing in the display, then let go of all the keys.
10.	Press the ↓ key until “LEVL” is showing in the display.
11.	Hold in the ‘*’ key, while holding in the ‘*’ key press the ↓ key until “1” is showing in the display, then let go of all the keys.
12.	Press the ↑ key until “SEt.2” is showing in the display.
13.	Hold in the ‘*’ key, while holding in the ‘*’ key press the ↑ or ↓ key until “5.0” is showing in the display, then let go of all the keys.
14.	Press and hold in both the ↑ and ↓ keys until the temperature is showing again.

3.5 Timer Controls

The 100 hour timer works with Channel 1 only, it has no effect on Channel 2.



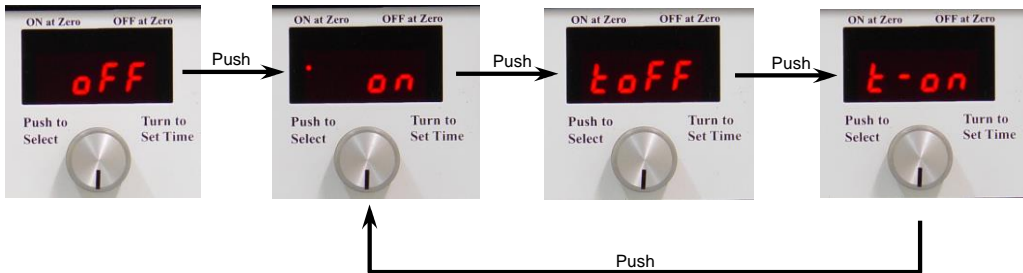

The timer circuit works in conjunction with the digital meter to determine when power is applied to the heater. The digital meter is the actual temperature controller, the timer circuit only acts as a *gatekeeper* to determine if the digital meter (temperature controller) is allowed to apply power to the heater or not. By inserting the timer between the digital meter and the heater, the timer can turn heater power On or Off based on a user entered time.

When power to the controller is turned on, the timer defaults to the *Power Off* state as is indicated by the word Off in the display. In this state no power is applied to the heater. This is a safety feature that insures that power is not applied to a heater following recovery from a power failure.

The timer has 4 states and cycles between the states by pushing the silver timer knob momentarily. For example, push the timer knob once and the timer changes from the Off state to the On state, push it again and it changes to the toFF state. Repeatedly pushing the knob cause the time to cycle between its three normal states of On, toFF, and t-on. If the Power Reduction Circuit (Section 3.6) is set to the Heat Off position, the timer window always displays oFF. The four states of the timer circuit are explained below.



NOTE: Pushing in on the timer knob quickly for about 1/4 second causes it to advance to the next state. Holding in the knob for 1 second changes to the mode where time is entered into the timer.

	<p>In the off state, no power is applied to the heater, even if the temperature meter calls for power to be applied. The controller always enters the off state when power is turned on or following recovery from a power failure. The controller also enters the off state when the power reduction circuit is set to the Heat Off position (see Section 3.6).</p>
	<p>In the on state, the timer circuit applies power to the heater when the temperature meter calls for power to be applied. Whenever power is applied to the heater, the small LED <i>dot</i> on the left of the timer window is lit. Depending on the power needs of the heater, this dot may blink rapidly.</p>
	<p>The “toFF” state (standing for <u>T</u>ime <u>O</u>ff) allows the user to enter the amount of time the controller should heat until heating is automatically turned off. While time is present in the timer, power is applied to the heater, when the time counts down to 0, heating is turned off. See the section below titled Heating for a Set Period of Time.</p>
	<p>The “t-on” state (standing for <u>T</u>ime <u>O</u>n) allows the user to enter an amount of time to delay before applying power to the heater. While time is present in the timer, no power is applied to the heater even if the temperature meter calls for power to be applied, but when time counts down to 0, heat is turned on indefinitely. See the section below titled Delay Heating for a Set Period of Time.</p>

Heating for a Set Period of Time

In this mode, the user enters the amount of time to heat before turning heating off permanently. This is useful to heat a reaction or other lab instrument for a set period of time and then have the reaction stop heating automatically.

While at this setting and while entering a time into the timer, no power is applied to the heater.



Step 1. When the timer displays “toFF”, holding in the timer knob causes the display to change to a clock showing 00 : 00. The left 2 digits are hours and the right 2 digits are minutes. The minutes digits are blinking which indicates that their value can be changed.

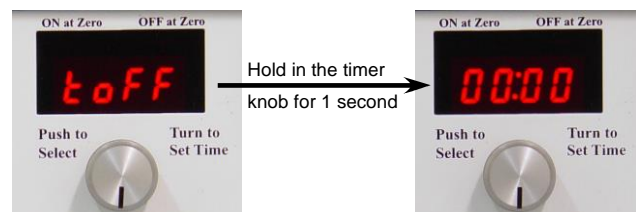

Step 2. To increase the number of minutes, rotate the timer knob to the right. To decrease the number of minutes, rotate the timer knob to the left.

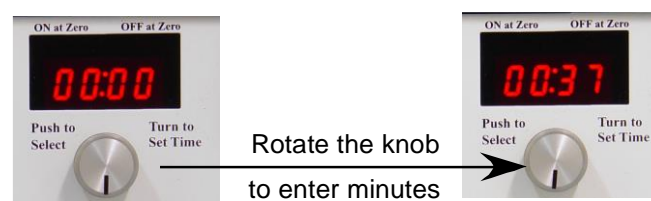

Step 3. To change the number of hours in the display, momentarily press the timer knob (1/4 second) and the hours digits begin to blink. To increase the number of hours, rotate the timer knob to the right. To decrease the number of hours, rotate the timer knob to the left.

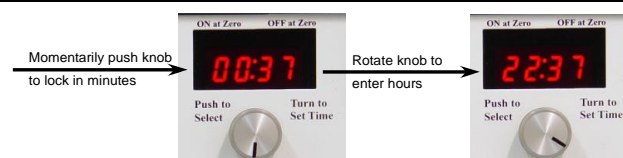

Step 4. When the desired time is displayed, hold in the timer knob for 1 second to enter the time and start the timer. When the timer starts, the LED under the label “OFF at Zero” lights. This indicates that power to the heater will turn OFF when the timer counts down to zero.

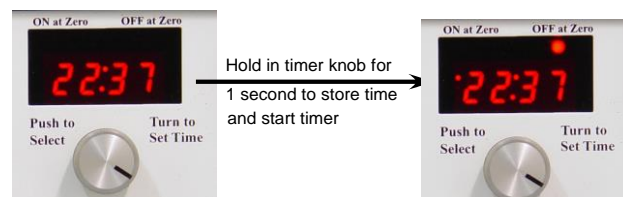

At any time, the timer program can be aborted by holding in the timer knob for 1 second. When this is done, the display changes to toFF. To turn on heating, push the timer knob twice until the display reads On.

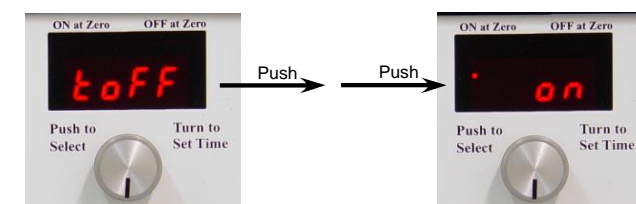

Delay Heating for a Set Period of Time

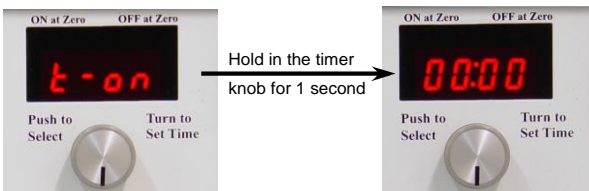
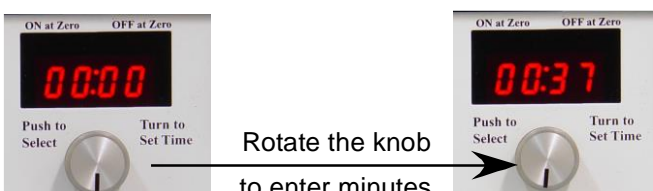
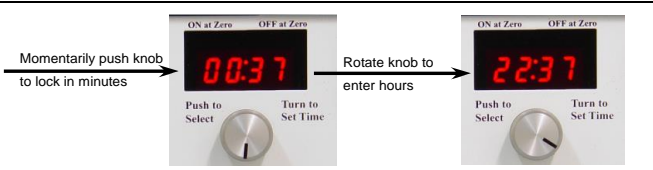
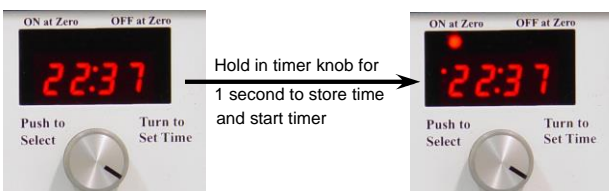
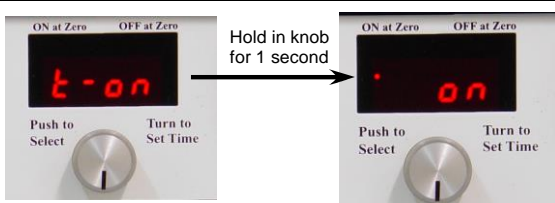
<p>In this mode, the user enters an amount of time to delay before turning on power to the heater. This is useful to start heating a reaction or piece of equipment automatically at a specific time. While at this setting and while entering a time into the timer, no power is applied to the heater.</p>	
<p>Step 1. When the timer displays “t-on”, holding the timer knob in for 1 second causes the display to change to a clock that shows 00 : 00. The left 2 digits are hours and the right 2 digits are minutes. The minutes digits are blinking which indicates that their value can be changed.</p>	
<p>Step 2. To increase the number of minutes, rotate the timer knob to the right. To decrease the number of minutes, rotate the timer knob to the left.</p>	
<p>Step 3. To change the number of hours in the display, momentarily press the timer knob (1/4 second) and the hours digits begin to blink. To increase the number of hours, rotate the timer knob to the right. To decrease the number of hours, rotate the timer knob to the left.</p>	
<p>Step 4. When the desired time is displayed, hold in the timer knob for 1 second to enter the time and start the timer. When the timer starts, the LED under the label “ON at Zero” lights. This indicates that power to the heater will turn ON when the timer counts down to zero.</p>	
<p>At any time, the timer program can be aborted by holding in the timer knob for 1 second. When this is done, the display changes to t-on. To turn on heating, push the timer knob until the display reads On.</p>	

3.6 Output Power Level This circuit (Figure 1, #'s 10 & 11) is the user's interface to J-KEM's patented power control computer which limits the maximum output power delivered by the controller. It determines whether the controller heats at a very low (1-10 mL), low (10 - 100 mL), intermediate (50 - 500 mL), medium (300 mL - 2 L), or high (>2 L) power level. The power level set for Channels 1 & 2 are independent of one another.

The output power circuit acts as a solid state variac. This circuit has an additional setting: “Heat Off” which, when selected, turns heating off and allows the controller to act as a digital thermometer. The table to the right shows the maximum output power from the controller to the heater depending on the position of the power switch. The correct setting for this switch is the setting that supplies adequate power for the heater to heat to the set point in a reasonable period of time while at the same time not overpowering it. See Section 4.4 for a detailed explanation of how to correctly set up a reaction using your J-KEM controller.

Heating Liquids. Each power level is associated with a volume range which acts as a guide when heating solutions with heating mantles. When solutions are heated with heating mantles set the power switch to the range that includes the volume of solution being heated [Note: this switch is set to the volume of solution, not the size of the flask]. For example to heat 250 ml of toluene to 80° C in a 1 L round bottomed

Front Panel Volume Range	Approx. % of Full Power
1 - 10 mL	3
10 - 100 mL	10
50 - 500 mL	25
300 ml - 2 L	50
≥ 2 L	100

flask choose the third power setting (50 - 500 ml) since the solution volume falls within this range. There are situations when a power level other than that indicated on the front panel should be used:

Example	Power Setting	Explanation
80 ml toluene 100 ml flask 100 ml heating mantle SP = 80° C	50 - 500 ml (25% power)	Organic solvents heated to ≈ 50 - 110° C are set to the volume range on the front panel. When choosing between 2 power settings (i.e. 80 ml also falls within both the 10 - 100 ml range and the 50 - 500 ml range) choose the higher setting.
80 ml collidine 100 ml flask 100 ml heating mantle SP = 170° C	300 ml - 2 L (50% power)	Even though the solvent volume is less than the range of this power setting, it should be used because high temperatures require additional power.
80 ml water 100 ml flask 100 ml heating mantle SP = 80° C	300 ml - 2 L (50% power)	While the setting 50 - 500 ml would work, since the heat capacity of water is twice that of a typical organic solvent (1 cal/g/° K), a higher power setting can be used to compensate for the higher heat capacity.
125 ml toluene 1 L flask 1 L heating mantle SP = 80° C	10 - 100 ml (10% power)	When the heating mantle size is substantially larger (≥ 5X) than the volume being heated (i.e. the heating mantle has excess heating capacity for the volume being heated), a lower power setting gives better control.
150 ml toluene 250 ml flask 250 ml heating mantle SP = 35° C	10 - 100 ml (10% power)	Even though the solvent volume isn't included in this power setting, it should be used because low temperatures are better regulated with less power.

Avoid switching between power levels while the controller is heating. Specifically, do not initially set the controller on a high power level to rapidly heat the solution, then decrease the power level to the correct setting as the solution approaches the set point. Changing power levels doesn't damage the controller, but it will reduce its heating performance.

Heating Equipment. Two factors need to be considered when heating equipment (ovens, hot plates, furnaces, HPLC columns, etc.); (1) placement of the temperature sensor (Section 2.4) and, (2) the appropriate power setting. The best guide to the correct power setting for various pieces of equipment is the researcher's experience. If your best guess is that the equipment needs 1/3 full power to heat to the set point, set the power switch on the 300 ml - 2 L setting (i.e., 50% power, it's usually better to have too much power rather than too little). If the heater heats too slow, increase the power (to the >2 L setting), if it heats too fast or has excessive overshoot, decrease the power (to the 50 - 500 ml setting). If the amount of power seems to be adequate, but the heater doesn't heat with stability, the controller probably needs to be tuned (see Section 2). Section 3.8 shows the type of performance you should expect from the controller with different pieces of equipment.

3.7 Temperature Sensor Input. Both channels of the controller are fitted with a specific *type* of thermocouple input and can only be used with a thermocouple of the same type. For the correct temperature to be displayed, the thermocouple type must match the receptacle type on the front of the controller (Figure 1; #'s 8 & 12). All thermocouples are color coded to show their type (Blue = type T; Yellow = type K; Black = type J). The color of the thermocouple plug must match the color of the receptacle on the front of the controller. If the thermocouple is broken or becomes unplugged, the error message "inPt" "FAiL" blinks in the temperature meter display and the controller stops heating.

3.8 Affect of Power Setting on Heating Profile. The following graphs show the affect of selected power levels on heating performance in a variety of situations. Each example contains 1 optimal and 1 or 2 less optimal settings demonstrating use of the output power level.

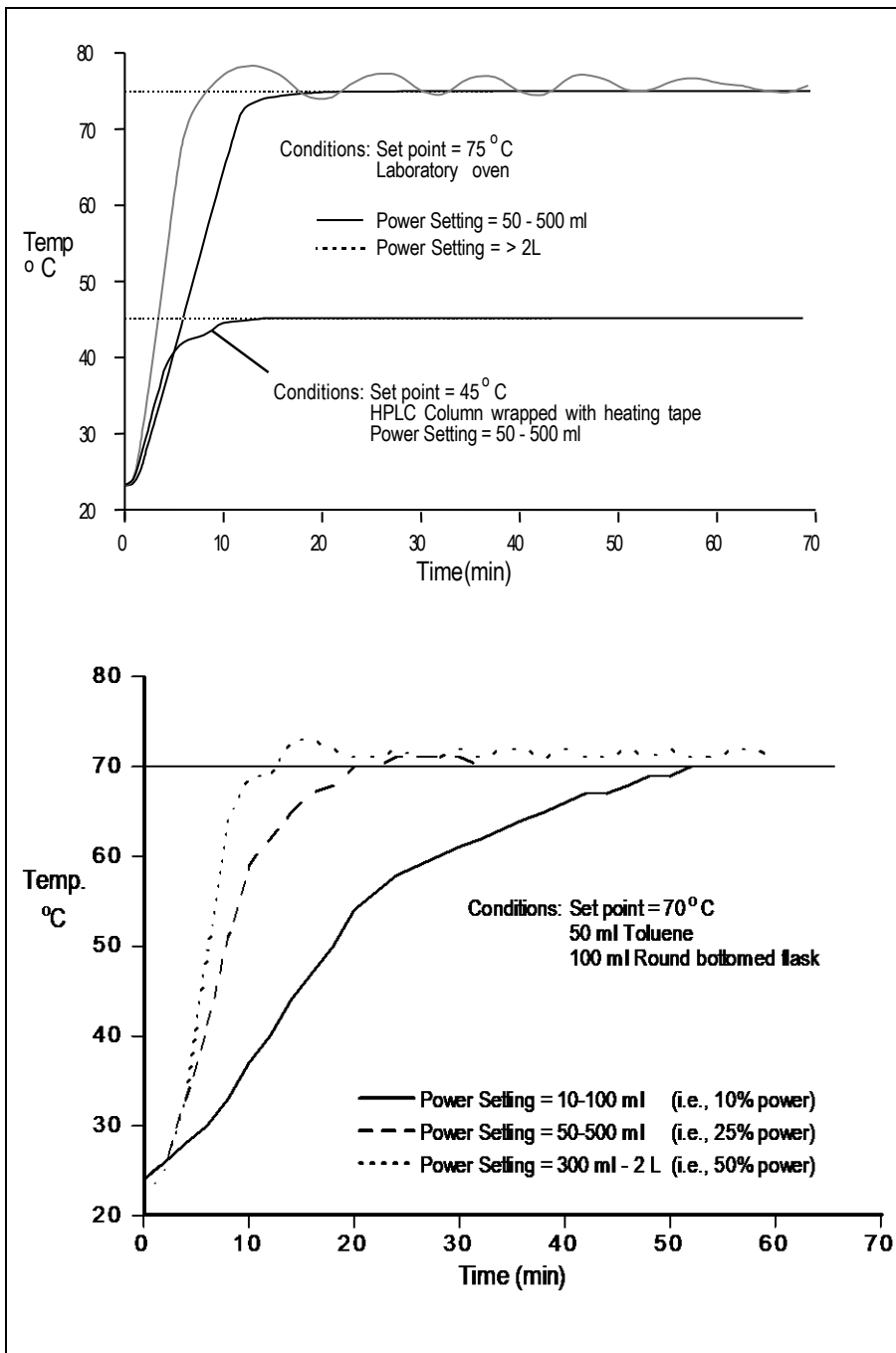

Graph 1

This graph shows typical heating profiles for a laboratory oven and an HPLC column. In the example of the oven the heating curves for 2 different power levels are shown. The 50 - 500 ml setting is the appropriate amount of power to heat to 75° C and thus results in a smooth heating curve. The > 2L power setting is too much power and results in oscillation around the set point.

Graph 2

This graph shows the affect of different power settings when heating liquids with heating mantles. The 10 - 100 ml setting (10% power) is underpowered and results in slow heating. The 300 ml - 2 L setting (50% power) is too much power and results in sporadic control. The controller adapts to a wide range of power settings. In this example the power is varied by a factor of 5X, nevertheless, reasonable control is maintained in each case.

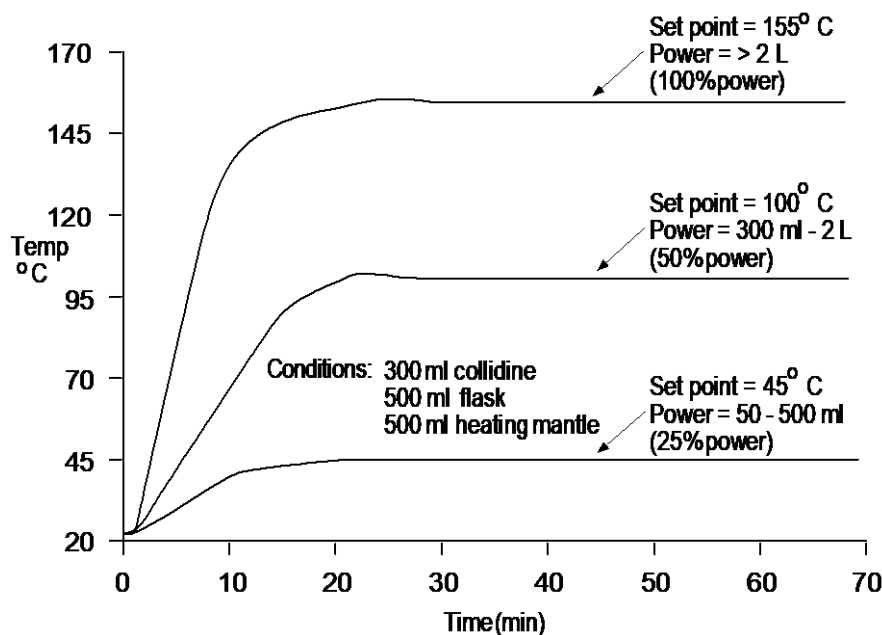

Graph 3

Another factor affecting the choice of power setting is the set point temperature. For set points near room temperature a low power level is adequate. For *average* temperatures (50 - 100°) the volumes printed on the front of the controller are a good guide. For high temperatures, the next higher power setting might be needed to supply the heater with additional power.

The output power level limits the total amount of power delivered to the heater. In this sense it works like a variac and can be used like one. If the heater isn't getting enough power, turn the power level up one notch, if it's getting too much power, turn it down.

3.9 Do's and Don'ts When Using Your Controller. The controller, heater and thermocouple form a closed loop feedback system (see Fig. 2 in Section 4.1). When the controller is connected to a heater, the feedback loop should not be broken at any point.

Don't	remove either the thermocouple or heater from the solution without setting the power level to the "Heat Off". With the thermocouple or heater separated from the solution, as the thermocouple cools the controller turns the heater on. Since this heat is never fed back to the controller it heats continuously.
Don't	use the controller to regulate an exothermic process. The controller has no capacity for cooling. If an exotherm is expected, it must be controlled in another way.
Do	use an appropriate size flask and heater for the volume being heated. Use the smallest flask and heating mantle that accommodates the reaction. This ensures that the heating power of the heating mantle closely matches the volume being heated. This also allows the solution to radiate excess heat to minimize temperature overshoots.
Do	place the thermocouple directly in the solution. Place at least the first 1/4" of the thermocouple directly into the solution. If a corrosive mixture is heated, use a coated-coated thermocouple (or use the external thermocouple method; Section 4.2).
Do	avoid exposure of the controller to corrosive gases and liquids. The atmosphere of a research hood is corrosive to all electronics. Place the controller outside the hood away from corrosive gases.

3.10 Resetting the Controller for Use With Heating Mantles.

If you want to use your controller with heating mantles after it's been tuned for a different style heater, rather than autotuning the controller with the heating mantle, J-KEM recommends that the controller be manually tuned by following the procedure below.

Procedure 4. Perform when using heating mantles with round bottomed flasks.

[This procedure takes about 2 minutes to perform]

1.	Press and hold in both the \uparrow or \downarrow keys on the front of the temperature meter for the channel you want to change until the word "tunE" appears in the display, then release both keys.
2.	Press the \uparrow key once and the word "bAnd" will appear in the display. First hold in the '*' key, then while holding in the '*' key press the \uparrow or \downarrow key until the value "10" appears in the display, then let go of all the keys.
3.	Press the \uparrow key once and the word "int.t" will appear in the display. First hold in the '*' key, then while holding in the '*' key press the \uparrow or \downarrow key until the value "10" appears in the display, then let go of all the keys.
4.	Press the \uparrow key once and the word "dEr.t" will appear in the display. First hold in the '*' key, then while holding in the '*' key press the \uparrow or \downarrow key until the value "50" appears in the display, then let go of all the keys.
5.	Press the \uparrow key once and the word "dAC" will appear in the display. First hold in the '*' key, then while holding in the '*' key press the \uparrow or \downarrow key until the value "3.0" appears in the display, then let go of all the keys.
6.	Press the \uparrow key once and the word "CyC.t" will appear in the display. First hold in the '*' key, then while holding in the '*' key press the \uparrow or \downarrow key until the value "30" appears in the display, then let go of all the keys.
7.	Press and hold in both the \uparrow or \downarrow keys until the temperature appears in the display, then release both keys.

3.11 Changing the Temperature Display Resolution The controller is programmed to display temperature with 0.1° C resolution. The controller can be changed to 1° C resolution if by following the procedure below (the display can also be changed to read in ° F, call for information). There are two reasons to change the display resolution:

- 1) To enter a setpoint faster (the display scrolls 10X faster in 1° mode than in 0.1° mode).
- 2) To display temperatures above 999.9°.

1.	Press and hold in both the \uparrow or \downarrow keys on the front of the temperature meter until the word "tunE" appears in the display, then release both keys.
2.	Press the \downarrow key once and "LEVL" appears in the display. First hold in the '*' key, then while holding in the '*' key press the \uparrow key until "2" appears in the display then let go of all the keys.
3.	Press the \uparrow key repeatedly until the word "diSP" appears in the display. First hold in the '*' key, then while holding in the '*' key press the \uparrow or \downarrow key until the value "1" [not "0.1"] appears in the display, then let go of all the keys.
4.	Press and hold in both the \uparrow or \downarrow keys until the temperature appears in the display, then release both keys.

3.12 Changing Between PID and ON/OFF Operating Modes. The controller can heat in either of 2 operating modes, PID (Proportional, Integral, Derivative) or ON/OFF mode. The difference between them is the way they supply power to the heater.

In ON/OFF mode (the simplest heating mode), the controller is ON when it's below the set point and OFF when above. The disadvantage of this mode is a large overshoot of the set point (5 - 30°) on initial warm up and oscillation of temperature around the set point thereafter. The reason for the overshoot is because the heater turns off only after crossing the set point and until the heater cools down the temperature continues to rise. This method works well for heaters that transfer heat rapidly (such as heat

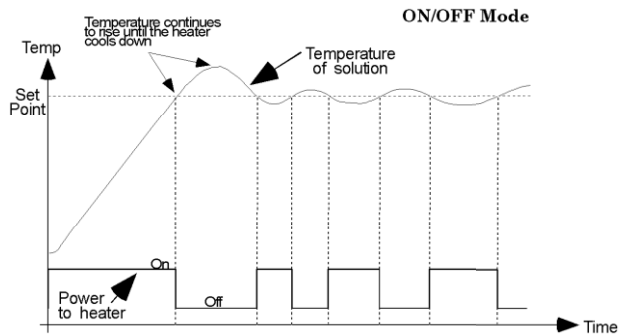

lamps), it's acceptable for heaters such as heating mantles (≈ 5° overshoot), but it's terrible for heaters that transfer heat slowly (vacuum ovens, heating blocks, etc.).

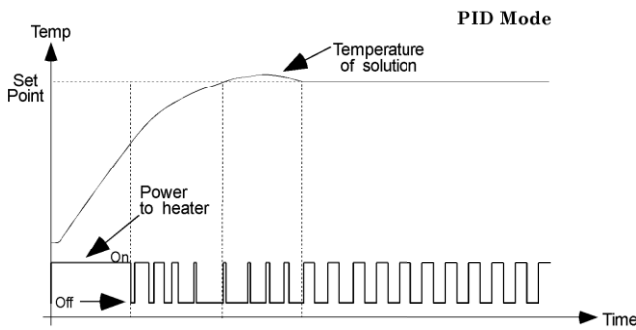

In PID mode the controller monitors the shape of the heating curve during initial warm up and decreases power to the heater before the set point is reached so that the solution reaches the set point with minimal overshoot. [Notice that the heater turns off for varying periods of time before the set point temperature is reached]. The second feature of PID mode is that it adjusts the percent of time the heater is on so that the set point is maintained precisely. The advantage of PID mode is that it delivers stable temperature control with any heater

from heat lamps to vacuum ovens. The disadvantage is that the controller must be properly tuned to the heater being used, whereas ON/OFF mode requires no tuning. Since both heating modes have their advantages (simplicity vs. accuracy), instructions to change the controller to ON/OFF mode are given below (though PID mode will probably give better results 95% of the time). The controller can be set back to PID mode by following Procedure 4 in Section 3.10.

- | |
|--|
| 1. Press and hold in both the ↑ or ↓ keys on the front of the temperature meter for the channel you want to change until the word "tunE" appears in the display, then let go of the buttons. |
| 2. Press ↑ until the word "CyC.t" appears in the display. |
| 3. While holding in the * key, press the ↓ key until the word "on.of" appears in the display. NOTE: if the display shows the letter "A" when the * key is held in, press the ↑ key until "on.of" is in the display, then let go of all the keys. |
| 4. Press the ↓ key until the word "bAnd" appears in the display. While holding in the * key, press the ↓ key until the value "0.1" appears in the display, then let go of all the keys. |
| 5. Press and hold in both the ↑ or ↓ keys on the front of the controller until the temperature is displayed, then release both keys. |

Procedure to change controller to ON/OFF mode



The controller can be set back to PID control by following Procedure 4 in Section 3.10. To completely reset the controller to original factory settings, follow the procedure in the Appendix, Section II.

3.13 Optional Safety and Automation Features.

Loop Break Alarm Feature.

The loop break alarm (LBA) feature guards against two mistakes that often result in catastrophic heating accidents. The first mistake is when a user sets up a reaction, enters the desired setpoint, and then accidentally forgets to put the thermocouple into the solution and leaves it sitting on the lab bench. In this case, the controller begins to heat the reaction, but since it never measures any increase in the reaction temperature, it heats at full power causing a heating accident or fire. A second scenario is that the flask breaks causing the thermocouple to fall out of the flask. In this case, the controller measures a sudden decrease in temperature, and so it properly starts to power the heater, eventually at full power. In both cases, the controller would not detect a heating error, and so it powers the heater, heating uncontrollably. The loop break alarm feature tracks when power is applied to the heater but the temperature of the thermocouple does not increase. After a short test period if the thermocouple doesn't show a continued increase in temperature, an error is declared and power is removed from the heater until the controller is manually reset by the user.

KEM-IO Feature

	<p>KEM-IO adds new features to your controller that allow it to operate other pieces of equipment based on time, temperature changes, external inputs, or serial commands. For example, KEM-IO can turn on a pump if the reaction temperature reaches a certain value, or turn off a stirrer after 3 hours, or if the solution temperature falls below 60° C.</p>																																																																						
 <table border="1"><thead><tr><th colspan="7">IO Logic Operations</th></tr><tr><th></th><th>Input</th><th>State</th><th>Action</th><th>State</th><th>Setpoint</th><th>Output Type</th></tr></thead><tbody><tr><td>If Input</td><td>Input 1</td><td>Goes Low</td><td>Change SP</td><td>None</td><td>50.0</td><td>Latching</td></tr><tr><td>If Input</td><td>Input 2</td><td>Goes High</td><td>Duilet 2</td><td>On</td><td></td><td>Non-Latching</td></tr><tr><td>▶ If Input</td><td>None</td><td></td><td></td><td></td><td></td><td></td></tr></tbody></table> <table border="1"><thead><tr><th colspan="7">IO Temperature Operations</th></tr><tr><th></th><th>Condition</th><th>Temp [oC]</th><th>Output</th><th>State</th><th>Action</th><th>Suppress</th></tr></thead><tbody><tr><td>If</td><td>Above</td><td>130.0</td><td>Output 2</td><td>Turn On</td><td>Latching</td><td><input type="checkbox"/></td></tr><tr><td>If</td><td>Below</td><td>85.0</td><td>Output 2</td><td>Turn Off</td><td>Non-Latching</td><td><input checked="" type="checkbox"/></td></tr><tr><td>▶ If</td><td>Above</td><td></td><td></td><td></td><td></td><td><input type="checkbox"/></td></tr></tbody></table>	IO Logic Operations								Input	State	Action	State	Setpoint	Output Type	If Input	Input 1	Goes Low	Change SP	None	50.0	Latching	If Input	Input 2	Goes High	Duilet 2	On		Non-Latching	▶ If Input	None						IO Temperature Operations								Condition	Temp [oC]	Output	State	Action	Suppress	If	Above	130.0	Output 2	Turn On	Latching	<input type="checkbox"/>	If	Below	85.0	Output 2	Turn Off	Non-Latching	<input checked="" type="checkbox"/>	▶ If	Above					<input type="checkbox"/>	<p>KEM-IO adds three hardware features:</p> <p>Digital Inputs can be used to instruct the controller to change its setpoint or turn a stirrer on when the hood door is opened, cooling water is lost, or a GC makes an injection.</p> <p>Digital Outputs can be used to Open/Close valves or turn On/Off other pieces of equipment based on a measured temperature, time, or the state of an input.</p>
IO Logic Operations																																																																							
	Input	State	Action	State	Setpoint	Output Type																																																																	
If Input	Input 1	Goes Low	Change SP	None	50.0	Latching																																																																	
If Input	Input 2	Goes High	Duilet 2	On		Non-Latching																																																																	
▶ If Input	None																																																																						
IO Temperature Operations																																																																							
	Condition	Temp [oC]	Output	State	Action	Suppress																																																																	
If	Above	130.0	Output 2	Turn On	Latching	<input type="checkbox"/>																																																																	
If	Below	85.0	Output 2	Turn Off	Non-Latching	<input checked="" type="checkbox"/>																																																																	
▶ If	Above					<input type="checkbox"/>																																																																	
<p>Serial Channels allow KEM-IO to send commands to other pieces of equipment. For example, if an exotherm is detected, KEM-IO can stop heating and then send a serial command to a chiller to start and set its setpoint to -20° C. Or, to heat a reaction to 80° C, then start a stirrer and measure the time it takes for the reaction to heat to 100° C.</p>																																																																							

3.14 Troubleshooting.

Problem	Cause	Corrective Action
Large over shoot of the set point (> 3 ^o) during initial warm-up or unstable temperature control.	Output power level is set too high. (Make sure you've set the power level for the channel actually being used).	Set the output power level to a lower setting (see Section 3.6).
	Controller is not tuned for process being heated. (Make sure you've set the power level for the channel actually being used).	Tune the controller as outlined in Section 2.
The process heats too slowly.	Output power level is set too low.	Increase the output power level to the next higher setting (Section 3.6).
	The heater doesn't have enough power.	Replace with a more powerful heater. For assistance contact J-KEM.
The controller does not come on.	15 amp fuse on back has blown.	Replace the fuse on the back of the controller with a new 15 amp fuse.
	Internal 2 amp fuse has blown.	Not user serviceable. Have qualified electrician replace.
	Circuit breaker on back has tripped.	Allow to cool, then reset circuit breaker.
The controller comes on, but does not heat.	The timer controls are set incorrectly.	Change the position of switch 18 or enter a time into the timer. See Section 3.5.
	The heater is broken.	To verify that the controller is functioning properly, place the power level switch on the >2L setting and enter a set point of 100 ^o C. Plug a light into the outlet of the controller, then wait 1 minute. If the light comes on the controller is working properly.
Controller blinks: "inPt" "FAiL" "-AL-" "PArk" "tunE" "FAiL"	The temperature sensor is unplugged, excessively corroded or broken.	Clean or replace broken sensor.
	The process temperature is hotter than the alarm temperature.	Correct the over temperature condition. If audible alarm is sounding press the power level button for the channel who's power level LED is blinking. To permanently disconnect alarm see Section 3.6.
	Controller has been placed in "Park" mode.	1. Hold in both the ▲ and ▼ keys on the front of the J-KEM temperature meter until "tunE" appears in the display. 2. First hold in the "*" key, then while holding in the "*" key press the ▼ key until "oFF" appears. 3. Hold in the ▲ and ▼ keys until the temperature appears in the display.
	Autotune routine failed.	Turn off controller for 10 seconds. See Section 2.2.

<p>Displayed temperature is incorrect.</p> <p>[Note: Types 'K' & 'J' Thermocouples display negative temperatures, but are not calibrated for them]</p>	The controller has not warmed-up.	The display temperature reads low when the controller is first turned on, but will self-correct as it warms up. The controller can be used immediately since it will warm up during the initial stages of heating.
	Wrong type of thermocouple is plugged into controller.	Thermocouples are color coded. Thermocouple plug and thermocouple receptacle must be the same color (see Section 3.7).
	Corroded thermocouple connections.	Clean plug on thermocouple and receptacle on controller with sandpaper or steel wool.
	Corroded thermocouple.	If the temperature-measuring end of the thermocouple is corroded, discard thermocouple.
	Temperature display offset needed.	<p>To enter a controller display offset:</p> <ol style="list-style-type: none"> 1. Turn on controller. Allow to warm up for 30 minutes. 2. Record displayed temperature. 3. Press both the ▲ and ▼ keys on the front of the temperature meter for the channel you want to change until "tunE" appears, then let go of the keys. 4. Press the ▼ key until "LEVL" appears. 5. First hold in the "*" key, then while holding in the "*" key press the ▲ key until "3" is showing in the display, then let go of all keys. 6. Press the ▲ key until "ZEro" is showing in the display. 7. Note the current display offset (this is the number blinking in the display). 8. Calculate the new offset temperature using the equation: <p style="margin-left: 40px;"> $\begin{matrix} \text{New} & & \text{Current} \\ \text{Display} & = & \text{display offset} & - & \text{Displayed} & + & \text{Correct} \\ \text{Offset} & & \text{blinking in display} & & \text{temperature} & & \text{temperature} \end{matrix}$ </p> 9. First hold in the "*" key, then while holding in the "*" key press the ▲ or ▼ keys until the new offset temperature is showing, then let go of all the keys. 10. Press the ▲ and ▼ keys until the temperature is displayed.

Section 4: Application Notes

Supplemental application notes on the following topics are available by contacting J-KEM.

Application Note	Subject
AN1	How to heat oil baths with your controller. (Included in Appendix)
AN2	Changing the controllers thermocouple type.
AN3	Changing the heating outlet into a cooling outlet.
AN4	Using the controller for unattended fractional distillations.
AN5	Using the controller with inductive (motors, valves) loads.

- 4.1 Theory of How the Controller Works – Simply.** For the purpose of explaining how the controller works, the example of a solution heated with a heating mantle is used. The principles are the same for all heater types.

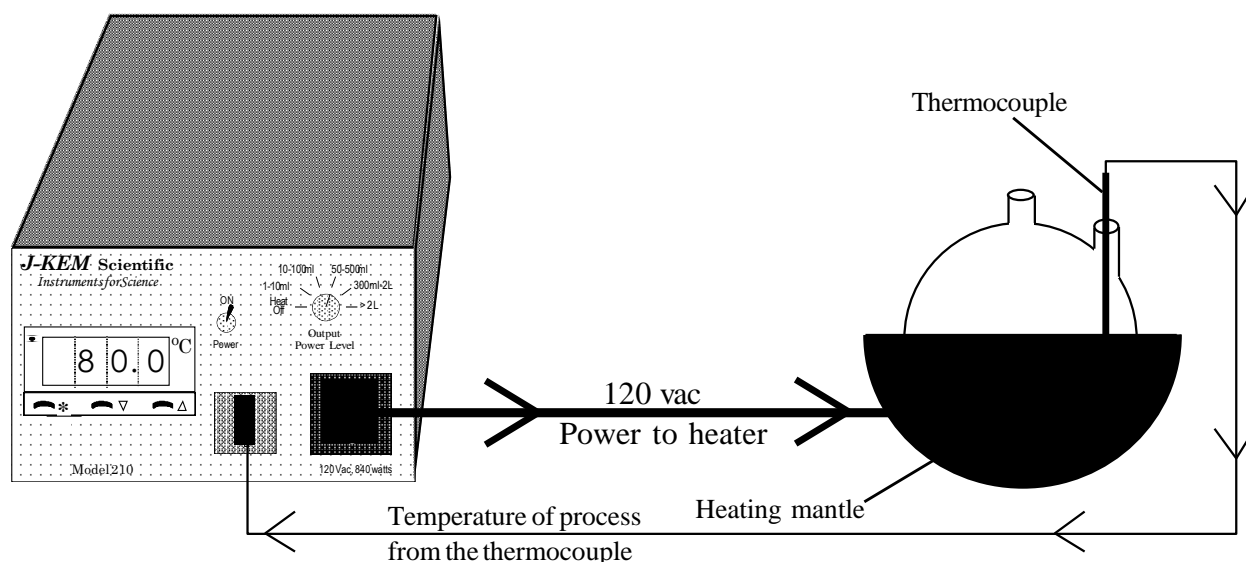

Figure 2

The controller, the heating mantle and the thermocouple form a closed loop feedback system. If the process temperature is below the set point, the controller turns the heating mantle on and then monitors the temperature rise of the solution. If a small rise results (indicating a large volume is being heated) the controller sets internal parameters appropriate for heating large volumes. If a large rise in temperature results, the controller responds by loading a set of parameters appropriate for heating small volumes. For the controller to work ideally, information needs to travel instantaneously around the feedback loop. That means that any power the controller applies to the heating mantle must reflect itself in an instantaneous temperature rise of the solution and the thermocouple. Unfortunately, this type of instantaneous heat transfer from the heating mantle to the solution to the thermocouple just doesn't occur. The delay time between when power is applied to the heating mantle and when the solution rises in temperature; and also the converse, when power is removed from the heating mantle and the solution temperature stops rising is the source of most controller errors. The reason for this can be seen in a simple example.

Imagine heating a gallon of water to 80° C in a 5 quart pan on an electric range. Placing the pan on the range and turning the heat to ‘high’ you’d observe a delay in heating while the range coil warmed-up. This delay might be a little annoying, but it’s really no problem. The real problem comes as the water temperature approaches 80° C. If you turned the range off just as the water reached 80° C the temperature would continue to rise – even though all power had been disconnected – until the range coil cooled down. This problem of overshooting the set point during initial warm-up is the major difficulty with process controllers. Overshooting the set point is minimized in two ways by your J-KEM controller – but first let’s finish the range analogy. If you had turned the range off just as the water temperature reached 80° C, the final temperature probably would not exceed 82° C by the time the range coil cooled down, because the volume of water is so large. In most situations a 2° C overshoot is acceptable. But what if you were heating 3 tablespoons (45 mL) of water and turned the stove off just as the temperature reached 80° C. In this case, the final temperature would probably approach 100° C before the range cooled down. A 20° C overshoot is no longer acceptable. Unfortunately, this is the situation in most research heating applications. That is, small volumes (< 2 L) heated by very high efficiency heating mantles that contain large amounts of heat even after the power is turned off. Your controller handles the problem of ‘latent heat’ in the heating mantle in two ways:

- 1) The controller measures the rate of temperature rise during the initial stages of heating. It then uses this information to determine the temperature at which heating should be stopped to avoid exceeding the set point. Using the range analogy, this might mean turning the power off when the water temperature reached 60° C and allowing the latent heat of the burner to raise the water temperature from 60° to 80° C. This calculation is done by the controller and is independent of the operator. The next feature of the controller is directly under operator control and has a major impact on the amount of overshoot on initial warm-up.
- 2) Again referring to the range analogy, you’d obtain better control when heating small volumes if the range had more than two power settings; Off and High. J-KEM’s patented output power level (5 & 13) serves just this function. It allows the researcher to reduce the power of the controller depending on the amount of heat needed. This circuit can be thought of as determining whether the heating power is **Very low** (1-10 mL), **Low** (10-100 mL), **Intermediate** (50-500 mL), **Medium** (300 mL-2 L), or **High** (> 2 L). The proper power setting becomes instinctive after you’ve used your controller for awhile. For additional information see Section 3.6.

4.2 Controlling a Heating Mantle Temperature Directly. In a *normal* heating setup, the thermocouple is placed in the solution being heated. The controller then regulates the temperature of the solution directly. The thermocouple could alternately be placed between the heating mantle and the flask so that the controller regulates the temperature of the heating mantle directly, which indirectly regulates the temperature of the solution.

Advantages to this method include:

1. The temperature of any volume (microliters to liters) can be controlled.
2. Temperature control is independent of the properties of the material being heated (e.g., viscosity, solid, liquid, etc.).
3. Air and water sensitive reactions can be more effectively sealed from the atmosphere.

The temperature meter must be programmed for use with an external thermocouple before this procedure is used (see following procedure). The following step-by-step procedure programs the controller to regulate heating mantle temperature. If you switch back and use the controller with the thermocouple in solution, Procedure 4 in Section 3.10 will program the controller for heating mantles. For all other heaters, see tuning instructions in Section 2.

After the controller is reprogrammed, place a fine gage wire thermocouple ($\approx 1/3$ the size of kite string; available from J-KEM) in the bottom third of the heating mantle and fit the flask snugly on top so that the thermocouple is in intimate contact with the heating mantle. Set the output power level to the power level shown in the table at the right. Turn the controller on and enter the set point.

Heating Mantle Size	Power Level
5 & 10 ml	1-10 ml
25 ml	10-100 ml
50 ml - 22 L	50 - 500 ml

For temperatures over ≈ 120 °C, the next higher power level may be necessary

Procedure to Load Tuning Parameters for External Thermocouples.

1.	Press and hold in both the \uparrow or \downarrow keys on the front of the temperature meter for the channel you want to change until the word "tunE" appears in the display, then release both keys.
2.	Press the \uparrow key once and the word "bAnd" will appear in the display. While holding in the "*" key press the \uparrow or \downarrow key until the value "5" appears in the display, then release all keys.
3.	Press the \uparrow key once and the word "int.t" will appear in the display. While holding in the "*" key press the \uparrow or \downarrow key until the value "2" appears in the display, then release all keys.
4.	Press the \uparrow key once and the word "dEr.t" will appear in the display. While holding in the "*" key press the \uparrow or \downarrow key until the value "5" appears in the display, then release all keys.
5.	Press the \uparrow key once and the word "dAC" will appear in the display. While holding in the "*" key press the \uparrow or \downarrow key until the value "5.0" appears in the display, then release all keys.
6.	Press the \uparrow key once and the word "CyC.t" will appear in the display. While holding in the "*" key press the \uparrow or \downarrow key until the value "5.0" appears in the display, then release all keys.
7.	Press and hold in both the \uparrow or \downarrow keys until the temperature appears in the display, then release both keys.

To return to using thermocouples in solution, perform Procedure 4 in Section 3.10.

- 4.3 Automatic Storage of Min/Max Temperatures** The controller will automatically record the minimum and maximum temperatures of a process by following the procedure below. These temperatures are updated continuously after the routine is started and cleared by turning the controller off. This procedure must be started every time you want to record temperatures.

Procedure to Start Temperature Logging	
1.	Press and hold in both the \uparrow or \downarrow keys on the front of the temperature meter for the channel you want to change until the word "tunE" appears in the display, then release both keys.
2.	Press the \downarrow key once and the word "LEUL" appears in the display. While holding in the "*" key press the \uparrow key until the value "3" appears in the display, then release all keys.
3.	Press the \uparrow key until the word "ChEy" appears in the display. While holding in the "*" key press the \uparrow key until "on" appears in the display, then release all keys.
4.	Hold in both the \uparrow or \downarrow keys until the temperature appears in the display, then release both keys. Automatic temperature logging is now on and will remain on until the controller is turned off or logging is turned off manually by repeating this procedure except in Step 3 pressing the \downarrow key until the word "off" appears.
Procedure to Read Minimum and Maximum Temperatures	
1.	Press and hold in both the \uparrow or \downarrow keys on the front of the temperature meter for the channel you want to change until the word "tunE" appears in the display, then release both keys.
2.	Press the \downarrow key once and the word "LEUL" appears in the display. While holding in the "*" key press the \uparrow key until the value "3" appears in the display, then release all keys.
3.	Press the \uparrow key until the word "rEAd" appears in the display. The "rEAd" screen displays 3 parameters. <ol style="list-style-type: none"> 1. Variance (the difference between the highest and lowest logged temperatures) Hold in the "*" key and the display will alternate between "UAr^o" and number of degrees of variance. 2. High Temperature (the highest temperature since the logging option was turned on). While holding in the "*" key press the \uparrow key once and the display will alternate between "hi ^o" and the highest recorded temperature. 3. Low Temperature. While holding in the "*" key press the \uparrow key once and the display will alternate between "Lo ^o" and the lowest recorded temperature. <p>The High and Lo temperatures can be examined as often as you like since updating and monitoring continues until the monitor is stopped by turning the controller off.</p>
4.	Press and hold in both the \uparrow or \downarrow keys until the temperature appears in the display, then release both keys.

4.4. How to Set Up a Reaction with J-KEM Scientific's Digital Temperature Controller

This application note shows how to set up a typical heated reaction using J-KEM Scientific's digital temperature controller. For this example, the Model Gemini controller is used, but the application note applies equally well to all J-KEM temperature controller models. If you have questions about specific models of temperature controllers, or any safety related question, please feel free to contact J-KEM Scientific. This application note does not supercede any information in the Controllers actual User manual. The User manual for each model is always the reference for that model.

The Model Gemini is a dual channel controller that allows two independent reactions to be run on the same controller, one reaction on Channel 1 and the second on Channel 2. In this example, we will only use channel 1.

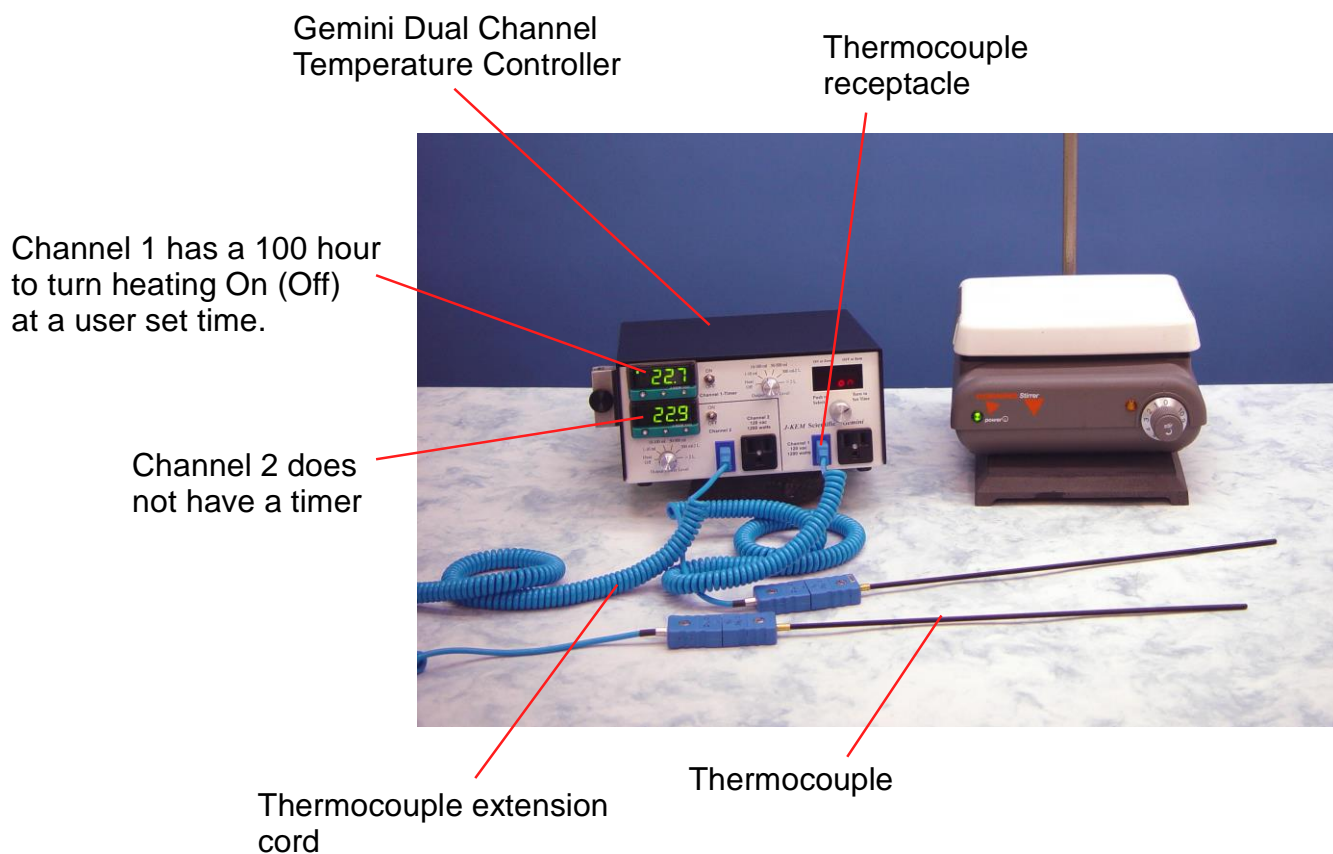

Thermocouples – Thermocouples are color coded. When the plastic connector on the end of the thermocouple is blue, it is a type T thermocouple, when it is yellow it is a type K, and when it is black it is a type J. The color of the thermocouple, the thermocouple extension cord, and the thermocouple receptacle on the face of the controller must all be the same color (i.e., thermocouple type) or the controller will not read the correct temperature. Thermocouples are available in many different styles. As long as the thermocouple has the same color connector as the connector on the controller, they are 100% compatible.

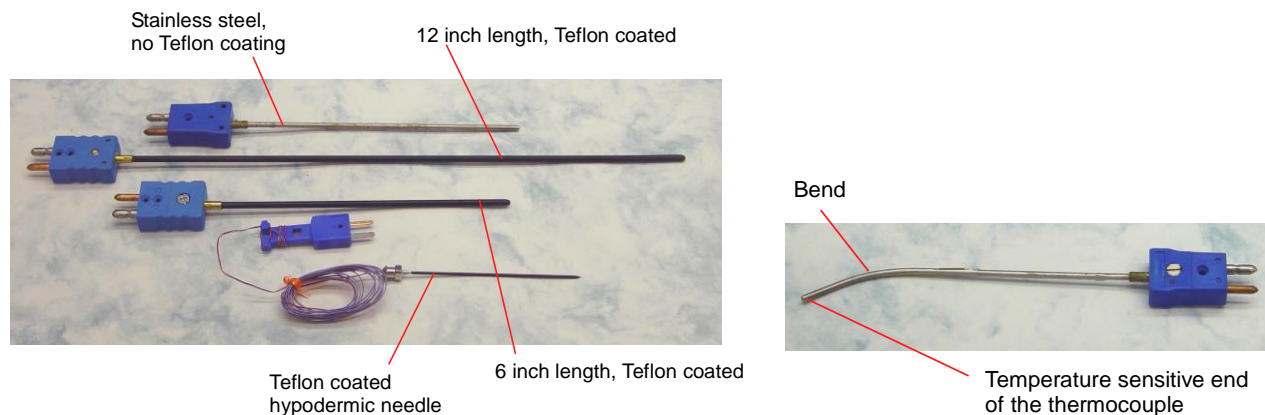

When a thermocouple is placed in solution, often it is desirable to bend the thermocouple slightly so that more of the tip extends into the solution. It does not hurt a thermocouple to be bent slightly. The temperature sensitive portion of a thermocouple is the first 1/4" of the tip. It's good for the first 1/2" to be in solution, but the first 1/4" must be in solution to read the temperature correctly.

Heaters – Your J-KEM controller works with virtually any 120 volt (or 230 volt heaters outside of the USA) heater, including any size heating mantle, 120 vac oil baths, hot plates, ovens, and many other style heaters. If you have questions about the compatibility of specific heaters, please contact j-KEM.



1 liter heating mantle

10 ml heating mantle

Oil bath

Classes of J-KEM Scientific Temperature Controllers

J-KEM's 200-Series, Apollo, and Gemini controllers are compatible with any size heating mantle from 5 ml to 50 liter, and any 120 Vac oil bath (do not use with oil baths rated less than 120 Vac).

J-KEM's 150-Series economy controllers are compatible with 500 ml heating mantles and larger, and 120 Vac oil baths (do not use with oil baths rated less than 120 Vac).

J-KEM's 230 Vac controllers are compatible with any 230 Vac heating mantle 100ml and larger. They are not compatible with any size oil bath.

Shown is a typical set up for a solution phase reaction.

1. Place the reaction flask in the appropriate size heating mantle., then plug the power cord from the mantle directly into the power outlet of the temperature controller.
2. Place a stirring bar inside of the flask, in the solution. Place the flask on a magnetic stirrer and stir the reaction for good heat transfer.
3. Place a thermocouple in solution and make sure that at least the first 1/4" (1/2" is better) is covered by the fluid in the reaction flask.

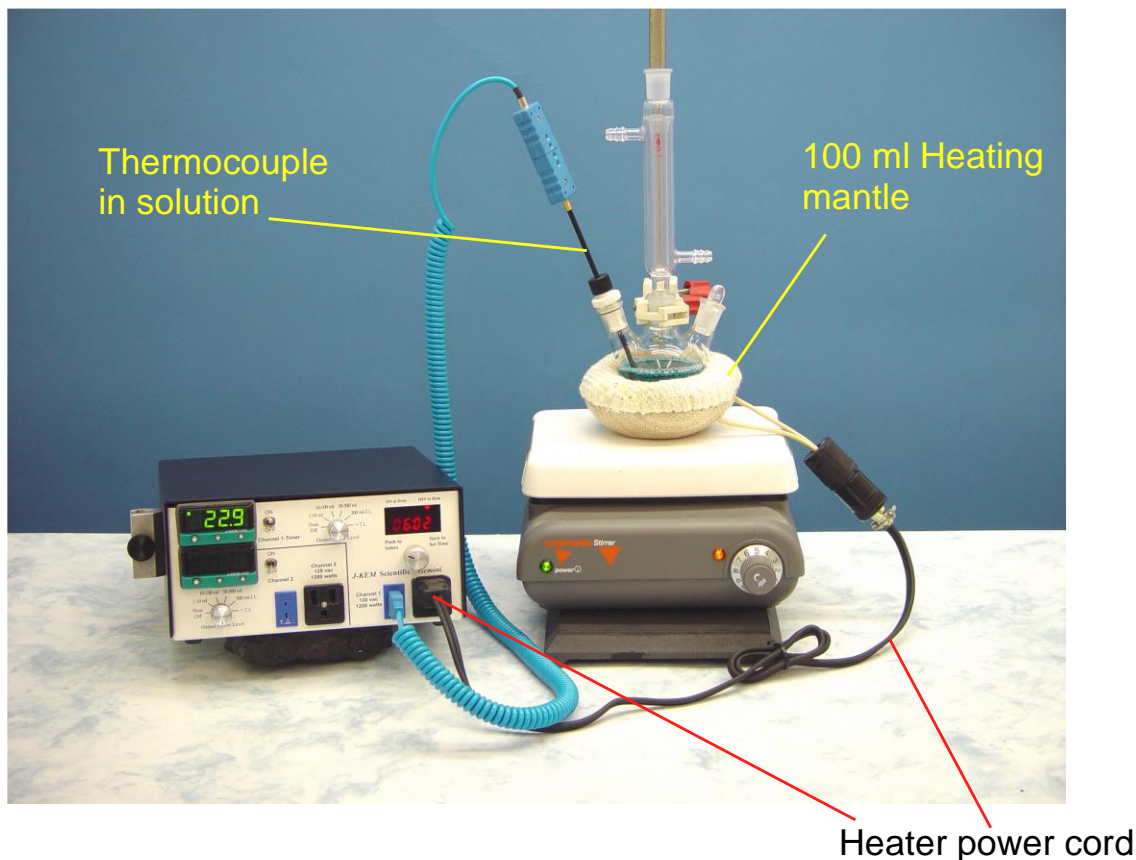

4. Enter the temperature that you want to heat the reaction to (i.e., the Setpoint) into the digital meter.

To enter the setpoint temperature (i.e., the temperature to heat to) into the controller:

1. Hold in the Star button on the face of the digital meter.
2. While holding in the Star button, press the Up arrow to increase, and the Down arrow to decrease the setpoint temperature.

When the desired setpoint temperature is showing in the display, release the star button to load the setpoint. When no buttons are pressed on the controller, the controller shows the temperature sensed by the thermocouple. When the Star button is pressed, the setpoint appears as a blinking number.

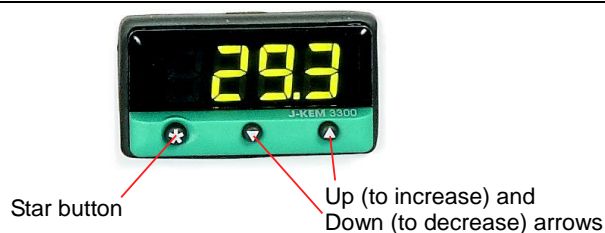

5. Set the correct Power Control Level. Your J-KEM controller has a built in Power Control Computer (PCC) that precisely regulates power to the heater. For the computer to work correctly, it must know the volume of solution that is being heated. It's important to understand that the PCC is set to the **Volume** of solution being heated, not the size of the heater or the size of the flask.



15 ml of solution in a 100 ml flask

If the flask above is placed in a 100 ml heating mantle, the power control input should be set to the "10-100 ml" setting.



The power control computer is always set to the **Volume** of solution being heated, not the size of the flask or heater.



75 ml of solution in a 100 ml flask

If the flask above is placed in a 100 ml heating mantle, the power control input should be set to the "50-500 ml" setting.

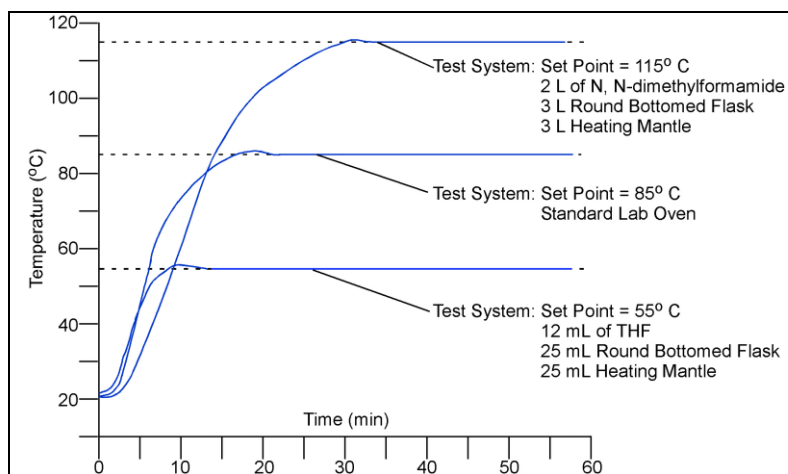

When the power control computer is set to the correct power level, your controller can regulate virtually any heater to $\pm 0.1^\circ\text{C}$ with less than 1°C overshoot on initial warming.

For a detailed explanation of the Power Control Computer, see Section Two in the controller's User manual.

Appendix

I. Using the Controller With an Oil Bath Application Note #1

Using your 200-Series controller with oil baths rated for less than 120 volt operation is not recommended. J-KEM manufactures a 400-Series controller designed for use with oil baths rated for any voltage and is recommended for this application. The 200-Series controller can be used with an oil bath rated for 120 volt operation without any special setup. Simply place the flask and the thermocouple directly in the oil, set the appropriate power setting and enter the reaction setpoint temperature..

If you need to use an oil bath with you J-KEM controller, J-KEM recommends the Instatherm oil baths. The two largest baths, Catalog #'s INS-150 and INS-160 are both rated for use with 120vac controllers and provide good temperature regulation.

If you frequently heat reactions using oil baths, we recommend J-KEM's 400-Series oil bath controller.

If the reason for using an oil bath is that a small volume is being heated, and you want to use your 200-Series controller for the job, you have a second option. J-KEM sells heating mantles for small volumes (5, 10, 25, 50 ml) which can be plugged directly into the temperature controller. Your controller regulates volumes as small as 1 ml in a 5 ml flask using a 5 ml heating mantle. If you need to heat even smaller volumes, your User's Manual describes a technique for heating microliters ("Controlling the Heating Mantle Temperature Directly"; in Section 4). The advantage of this option is that it eliminates the mess and safety hazards associated with oil baths. Accessories for regulating the temperature of small volumes are available from J-KEM including small volume heating mantles and micro thermocouples.

Call if you have any concerns or would like to discuss your application with a technical representative.

Accessories for Heating Small Volumes Available From J-KEM

Heating Mantles	All sizes from 5 ml to 50 L.
Teflon Coated Microscale Thermocouples	See Catalog.
Thermocouples hermetically sealed in various size hypodermic needles	See Catalog

II. Safety Considerations and Accurate Temperature Control

For safety critical and non-typical organic reactions (especially polymeric reactions) or for use with heaters other than heating mantles the user must either 1) monitor the reaction closely to verify the tuning parameters are appropriate for the current application, or 2) autotune the controller for the application. For any safety critical or high value reaction, call J-KEM to discuss your application with an engineer prior to beginning.

Your J-KEM controller is capable of regulating virtually any application to $\pm 0.1^\circ\text{C}$ if the controller is tuned to the application being heated. Since it's possible that the tuning parameters are not set correctly for your application, the user must monitor a new reaction to verify the controller's operation. A short primer on tuning is presented below, a more detailed explanation is presented in Sections 2.1 and 4.1.

Tuning is the process that matches the control characteristics of the controller to the heating characteristics of the process being controlled. The controller uses a PID (Proportional, Integral, Derivative) algorithm to regulate heating. Each of the terms in the PID equation have a constant that *scales* the equation to the process being heated. These constants (plus two other related terms) are collectively known as the 'tuning constants' and for the most part they are expressed in units of time, since they represent delay times, rate of heat transfer times, and rate of error accumulation. The relative value of each constant depends on the physical characteristics of the process being heated. For example, for the same amount of input power, the rate of heat transfer is twice as high for hexane as compared to water, since the coefficient of heat for hexane is $0.54\text{ calories/g}^\circ\text{C}$ and water is $1.0\text{ calorie/gram}^\circ\text{C}$. That means that 1000 watt-seconds of input power will raise the temperature of 10 g of hexane 44°C while the same amount of power causes a 24°C rise in water. In theory, the tuning constants needed to heat hexane are different from those to heat water. Fortunately, your J-KEM controller is self-adaptive and is able to adapt its heating characteristics for different solvents such as hexane and water. Even with the controller's self-adaptive algorithms, the tuning constants have to be reasonably close to a proper set or the controller will not produce stable temperature control (see Section 2.1).

When a controller is shipped, the default set of tuning constants loaded into the controller are those appropriate for heating *typical* organic reactions (i.e., small molecule chemistry in low boiling ($< 160^\circ\text{C}$) organic solvents) using heating mantles, since this is the most common application for J-KEM controllers. **Since it's impossible for J-KEM to predict the application the controller will be used for, the researcher must be aware of the possibility that the tuning constants loaded into the controller may not be a set that results in stable temperature control. It's the researcher's responsibility to monitor the temperature regulation of a reaction.** If you encounter a process that your J-KEM controller does not heat with stability, you have two resources.

Autotune Feature. Your controller has an autotune feature that when turned on (see Sections 2.1 & 2.2) automatically determines the proper tuning constants for your application and then loads them into memory for future use.

J-KEM Technical Assistance. If you have an application you wish to discuss, call us, we're always anxious to help our users.

For an additional description of the PID algorithm and the concept of tuning, see Sections 2 and 4.1.

III. The Effect of Power Level and Tuning on Control Stability

Your J-KEM temperature controller is capable of controlling the temperature of virtually any application with great precision. But, it's important to know how the controller works and how to adjust it when the controller needs to regulate *non-traditional* heaters, or heating applications. For any heating application, there are two critical considerations:

- 1) The maximum amount of power that should be applied to the heater.
- 2) The PID tuning parameters the controller is using.

All examples in this discussion use the same reaction set up:

10 ml of oil in a 25 ml round bottomed flask being heated with a 25 ml heating mantle.

Consideration 1: The maximum amount of power to apply to the heater

Most heaters used in research labs are greatly over-powered for the applications they are typically used for. For example, in our setup a 25 ml heating mantle has 60 watts of power at 120Vac, which is over 10 times too much power to heat a solution to typical (20 to 150C) reaction temperatures. One of the purposes of J-KEM Power Reduction Circuit (the silver knob on the front of the controller associated with volumes) is to precisely regulate the maximum power applied to the heater. The plot below shows the temperature profile that results when the power reduction circuit is set to the proper setting of "10-100 ml", which limits the heating mantles output power to about 5 watts, the correct amount of power needed in this application.

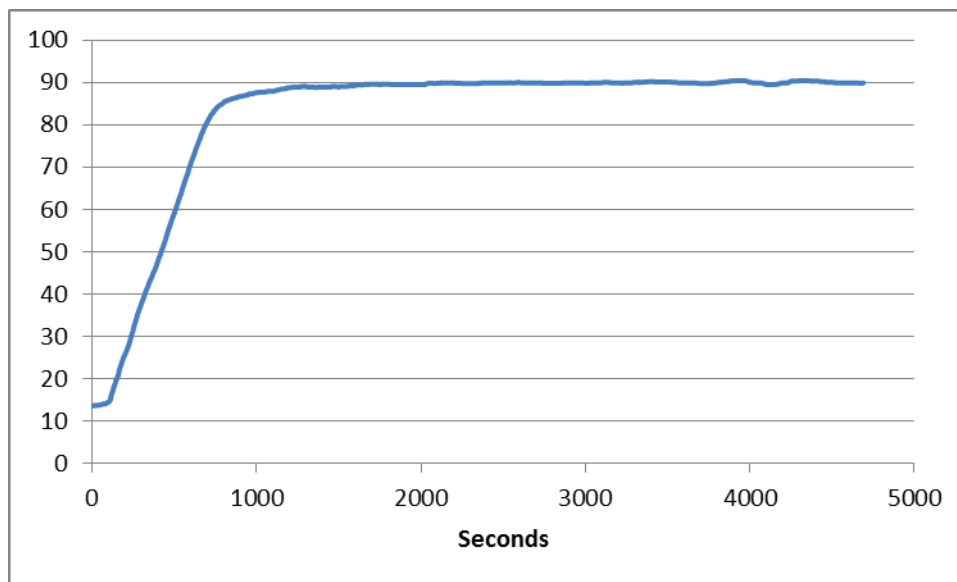

Consideration 2: The PID tuning parameters.

A thorough discussion of the PID algorithm is beyond the scope of this discussion, but a good explanation can be found in Wikipedia. Basically, PID parameters match the control characteristics of the controller to the heating characteristics of the heater. For example, consider the difference in heater characteristics between a gas and an electric kitchen range. When a gas range comes on, it comes on at 100% power instantaneously, and when it is turned off, 100% of the power is removed instantaneously.

In comparison, when an electric range is turned on, it may take 30 seconds before the burner even begins to warm, and maybe 3 minutes to get up to full heater power. Also, when it is turned off it may take 5 minutes to remove all heater power (i.e., cool). Your J-KEM controller can regulate both of these heater styles with high precision, but it needs to know which of the two heater styles it is powering. The PID parameters are used to describe the heat style.

Every heater has a unique set of tuning parameters, but it's not necessary to use the *perfect* set every time, which would require a lot of unnecessary setup of the controller. The J-KEM controller is highly adaptive so the *perfect* set of tuning parameters don't need to be loaded for stable temperature controller, the set just needs to be *close*. For example, even though every heating mantle size would have a different set of PID settings,

your controller is loaded with a single *good* set of parameters that provides ± 0.2 C regulation of all heating mantles sizes from 5 ml to 50 liters. This is possible because, as stated earlier, your controller is quite adaptable to different heating conditions.

The effects of power level and tuning parameters can be seen in the plots below.

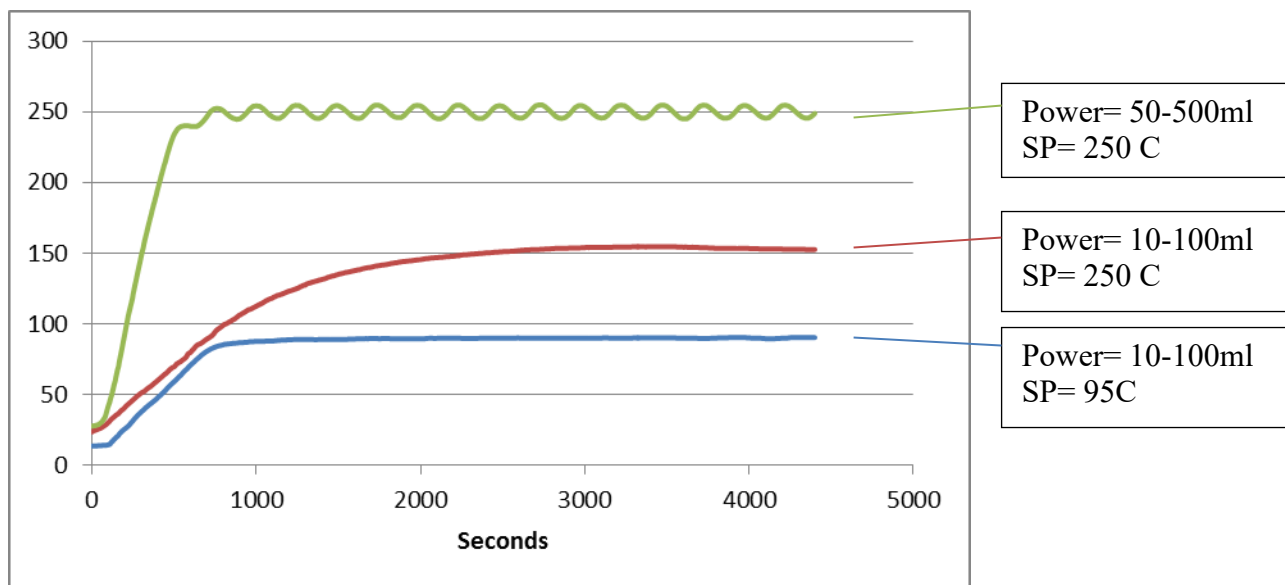

The bottom plot uses the standard set of PID values that results in stable temperature control at 95 C.

The second plot uses the same PID values, but the setpoint was changed to 250 C. As you can see, the heating mantle doesn't have enough power at the "10-100 ml" setting to heat the reaction to 250 C, and so it stalls out at about 150 C. The solution is to increase the power to the heating mantle.

The top plot shows the effect of increasing the controllers' power to the 50-500 ml setting (this changes the power delivered to the heating mantle from 5 watts to 12.5 watts). The issue now becomes that the standard set of PID values are not ideal to this increased power level, which is why the reaction temperature oscillates.

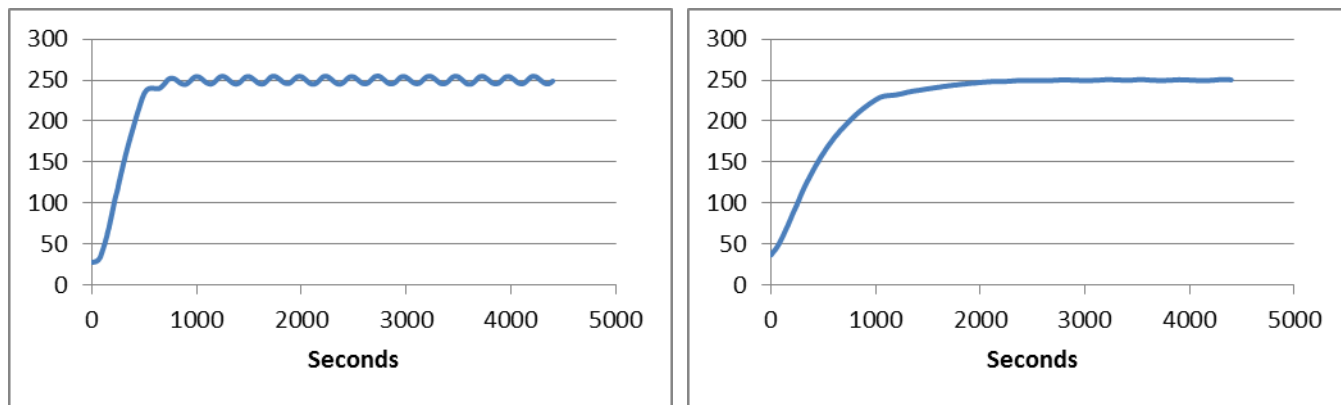

The answer to remove the oscillation shown in the chart on the left is to autotune the controller, which results in the temperature profile shown on the right.

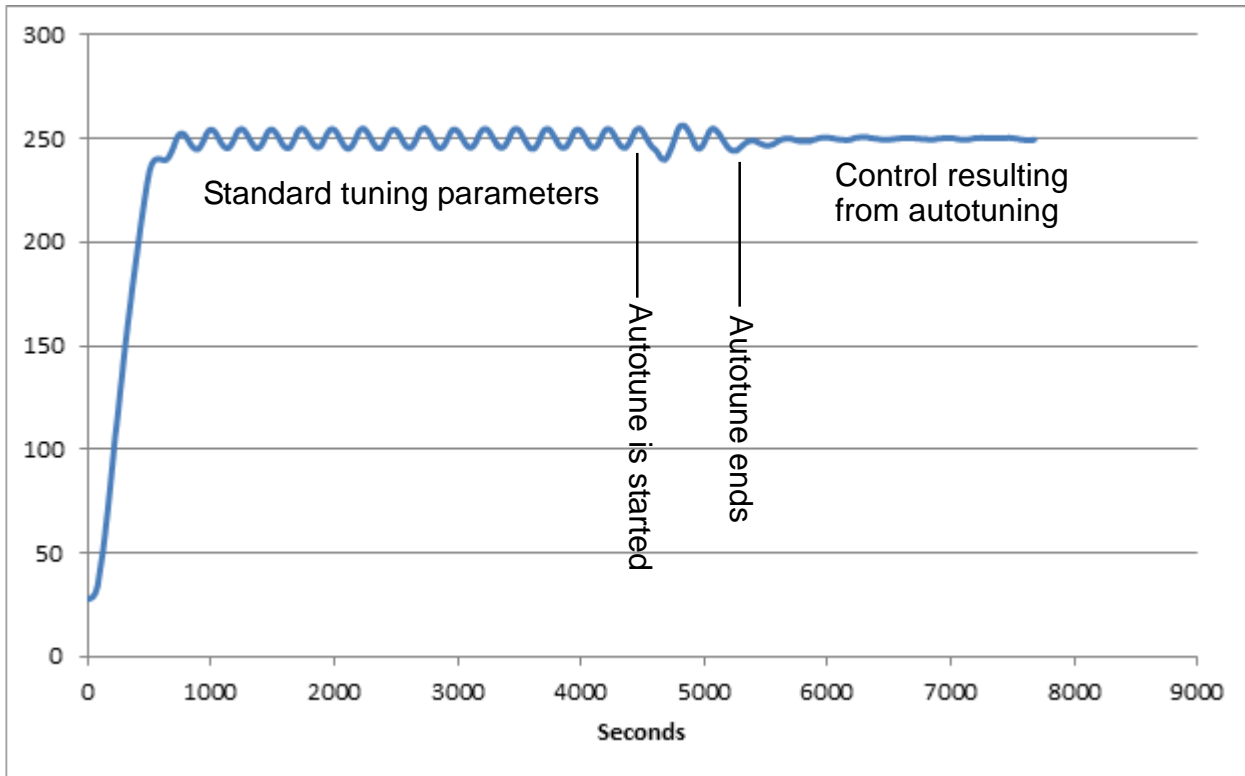

One final plot will help to demonstrate the effects of power and tuning. In the plot above, the same reaction setup is used, but the power applied to the heating mantle increased to the “300 ml – 2 setting (30 watts). This causes the system to heat much faster (the solution hits 240C in about 8 minute rather than 15 minutes when set to the 50 – 500 ml setting). But again, more than doubling the power applied to the heating mantles causes oscillation in the temperature profile. At about 4500 seconds, the autotune procedure (“autotune for fine control”) is started which once again results in stable temperature control.

J-KEM does not recommend autotuning the controller every time a unique heating application is needed, because in the example above, now that the controller is autotuned to 250C, it no longer has the PID values that are appropriate for the more standard temperature range of 20 – 150C. Practically, the controller should be loaded with the PID values that result in stable temperature control for the type of applications the controller is typically used for.

One Last Thing..... The style of thermocouple used for a heating process is very important. In the above cases, since the volume was small, we used a small, low thermal mass stainless steel needle tip thermocouple (Cat# HN-3.5-K). If we had used a standard probe style thermocouple that barely fit into the 10ml of solution volume, no heating profile would have worked well.

IV. Resetting the Controller to Original Factory Settings

J-KEM manufactures the most technically advanced temperature controller available and should give you consistently flawless control. If you have difficulty with your controller, a good place to start to correct the problem is by loading the original factory settings as detailed in the procedure below. If you still have difficulty with your controller, our Engineering Department will help you resolve the problem. Before beginning this procedure, plug a thermocouple into the channel being reset.

Procedure to Reset the Controller to Original Factory Settings

1.	Press and hold in both the ▼ and ▲ keys on the front of the temperature meter for the channel you want to change until the word “tunE” appears in the display, then release both keys.						
2.	Press the ▼ key until “LEVL” appears in the display. Next, hold in the ‘*’ key, then while holding in the ‘*’ key press the ▲ key until “3” appears in the display. Let go of all the keys.						
3.	Press the ▲ key until “rSEt” appears in the display. Next, hold in the ‘*’ key, then while holding in the ‘*’ key press the ▲ key until the word “All” appears in the display. Let go of all the keys.						
4.	<p>Press and hold in both the ▼ and ▲ keys until the word “inPt” appears in the display, then release both keys. During this step the over temperature alarm will begin to sound. It is turned off in Step 7. The value that needs to be entered depends of the type of thermocouple receptacle your controller was shipped with. Determine the thermocouple type below.</p> <p style="text-align: center;">Color of thermocouple receptacle (#’s 8 & 12) Value to enter:</p> <table style="margin-left: auto; margin-right: auto;"> <tr> <td style="padding-right: 20px;">Blue (type T)</td> <td>“tc 1 ”</td> </tr> <tr> <td>Yellow (type K)</td> <td>“tc 2 ”</td> </tr> <tr> <td>Black (type J)</td> <td>“tc 1 ”</td> </tr> </table> <p>Hold in the ‘*’ key, while holding in the ‘*’ key press the ▲ key until the value from above appears in the display. Let go of all the keys.</p> <p>NOTE: Many of the patterns for this parameter look similar, be careful to select the exact pattern shown above.</p>	Blue (type T)	“tc 1 ”	Yellow (type K)	“tc 2 ”	Black (type J)	“tc 1 ”
Blue (type T)	“tc 1 ”						
Yellow (type K)	“tc 2 ”						
Black (type J)	“tc 1 ”						
5.	Press the ▲ key once and “unit” will appear in the display. Next, hold in the ‘*’ key, then while holding in the ‘*’ key press the ▲ key until the value “0 C” appears in the display,. Let go of all the keys.						
6.	Press the ▲ key once and the word “SP1.d” appears in the display. Next, hold in the ‘*’ key, then while holding in the ‘*’ key press the ▲ key until the value “SSd” appears in the display. Let go of all the keys.						
7.	<p>Press in both the ▼ and ▲ keys until the temperature appears in the display (the word “PArk” also appears), then release both keys.</p> <p>To turn off the alarm, change the set point by holding in the ‘*’ key then hold in the ▲ key until a value > 100 is entered. Let go of all the keys. Press the Output Power Level button for the channel being reset. The alarm should turn off.</p>						
8.	Press and hold in both the ▼ and ▲ keys on the front of the temperature meter for the channel you want to change until the word “tunE” appears in the display, then release both keys.						
9.	Press the ▲ key once and the word “bAnd” will appear in the display. Next, hold in the ‘*’ key, then while holding in the ‘*’ key press the ▲ key until the value “10” appears in the display. Let go of all the keys.						
10.	Press the ▲ key once and the word “int.t” will appear in the display. Next, hold in the ‘*’ key, then while holding in the ‘*’ key press the ▲ key until the value “10” appears in the display. Let go of all the keys.						
11.	<p>Press the ▲ key once and the word “dEr.t” will appear in the display.</p> <p>Next, hold in the ‘*’ key, while holding in the ‘*’ key press the ▲ key until the value “50” appears in the display. Let go of all the keys.</p>						
12.	Press the ▲ key once and the word “dAC” will appear in the display. Next, hold in the ‘*’ key, then while holding in the ‘*’ key press the ▲ key until the value “3.0” appears in the display. Let go of all the keys.						
13.	Press the ▲ key once and the word “CyC.t” will appear in the display. Next, hold in the ‘*’ key, then while holding in the ‘*’ key press the ▲ key until the value “30” appears in the display. Let go of all the keys.						
14.	Press the ▲ key until the word “SPrn” appears in the display. Next, hold in the ‘*’ key, then while holding in the ‘*’ key press the ▼ or ▲ key until the word “OFF” is displayed. Let go of all the keys.						

15.	Press the ▼ key until the word “LEVL” appears in the display.
16.	First hold in the ‘*’ key, then while holding in the ‘*’ key press the ▲ key until “2” appears in the display. Let go of all the keys.
17.	Press the ▲ key until “SP2.A” appears in the display. Next, hold in the ‘*’ key, then while holding in the ‘*’ key press the ▲ key until the word “dV.hi” appears in the display. Let go of all the keys.
18.	Press the ▲ key until “diSP” appears in the display. Next, hold in the ‘*’ key, then while holding in the ‘*’ key press the ▼ or ▲ key until the value “0.10” appears in the display. Let go of all the keys.
19.	Press the ▲ key until “Lo.SC” appears in the display. Next, hold in the ‘*’ key, then while holding in the ‘*’ key hold in the ▼ key until the number in the display stops changing (this will be “0” or “-50” or “-199.9” depending on thermocouple type). Let go of all the keys.
20.	Press the ▼ key until the word “LEVL” appears in the display.
21.	First hold in the ‘*’ key, then while holding in the ‘*’ key press the ▲ key until “3” appears in the display. Let go of all the keys.
22.	<p>Press the ▲ key until “SPAn” appears in the display. Next, hold in the ‘*’ key, then while holding in the ‘*’ key press the ▼ or ▲ key until the correct value (see below) appears in the display. Let go of all the keys.</p> <p>If the TOP meter is being reset, enter the value: _____.</p> <p>If the BOTTOM meter is being reset, enter the value: _____.</p>
23.	<p>Press the ▲ key until “ZEr0” appears in the display. Next, hold in the ‘*’ key, then while holding in the ‘*’ key press the ▼ or ▲ key until the correct value (see below) appears in the display. Let go of all the keys.</p> <p>If the TOP meter is being reset, enter the value: _____.</p> <p>If the BOTTOM meter is being reset, enter the value: _____.</p>
24.	Press the ▼ key until the word “LEVL” appears in the display. Let go of all the keys.
25.	Hold in the ‘*’ key, then while holding in the ‘*’ key press the ▼ key until “1” appears in the display. Let go of all the keys.
26.	Press the ▲ key until “SEt.2” appears in the display. Next, hold in the ‘*’ key, then while holding in the ‘*’ key press the ▲ or ▼ keys until the value 5.0 is entered. Let of go of all keys.
27.	Press the ▲ key once to display “bnd.2” appears in the display. Next, hold in the ‘*’ key, then while holding in the ‘*’ key press the ▲ or ▼ keys until the value 0.1 is entered. Let of go of all keys.
28.	Press the ▼ key until the word “LEVL” appears in the display. Let go of all the keys.
29.	First hold in the ‘*’ key, then while holding in the ‘*’ key press the ▼ key until “C” appears in the display. Let go of all the keys.
30.	Press the ▲ key and “Addr” will appear in the display. Next, hold in the ‘*’ key, then while holding in the ‘*’ key press the ▼ or ▲ key until the value “1” appears in the display. Let go of all the keys.
31.	Press the ▲ key and “bAud” will appear in the display. Next, hold in the ‘*’ key, then while holding in the ‘*’ key press the ▼ or ▲ key until the value “9600” appears in the display. Let go of all the keys.
32.	Press the ▲ key and “dAtA” will appear in the display. Next, hold in the ‘*’ key, then while holding in the ‘*’ key press the ▼ or ▲ key until the value “18n1” appears in the display. Let go of all the keys.
33.	Press and hold in both the ▼ and ▲ keys until the temperature appears in the display, then release both keys.
34.	If the alarm is sounding, reset it by pressing the Output Power Level button for the channel being reset.